



SWOOD 2024

What's new

Review:

BETA 0

SWOOD 2024

What's new

The purpose of this document is to present the new features of SWOOD 2024, to define their parameters and, lastly, to provide explanatory videos for certain new features, so that they can be better understood.

How does this document work?

For each software (SWOOD Design, SWOOD CAM, SWOOD Nesting and SWOOD Report), you can click on a [bookmark](#), which will redirect you to the corresponding chapter in this document.

Global new feature

Simplified access to SWOOD Rx

EFICAD's team makes its best efforts to provide software that is as stable as possible, however, it does happen that some software functions fail. So that end users can report these bugs as accurately as possible, and so that developers can understand and correct them; EFICAD has developed a small utility to enable this: SWOOD Rx. In SWOOD 2024, SWOOD Rx is available more easily, directly in the software interface.

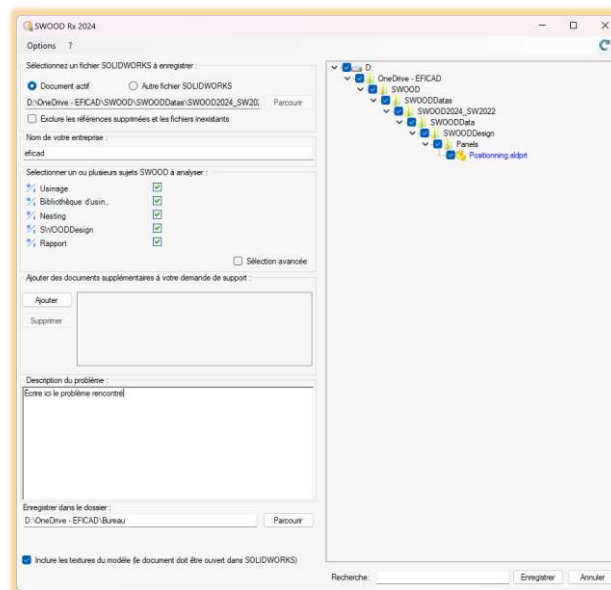

SWOOD Rx utility interface

SWOOD Design

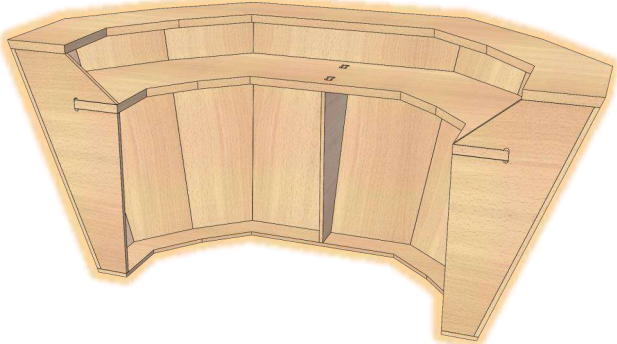
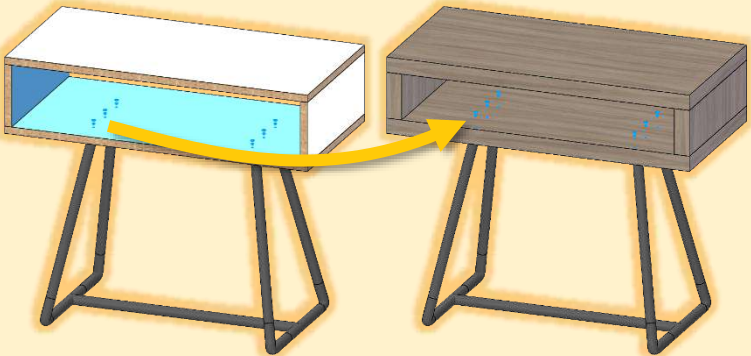
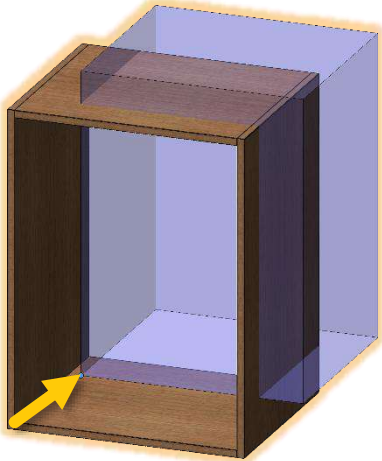
New feature	Description
<p>Panel Joint</p>	 A 3D cutaway diagram of a curved wooden cabinet. The diagram shows the internal structure, including the back panel and the side panels. A specific joint is highlighted where a panel meets the back panel, demonstrating the 'Panel Joint' feature.
<p>SWOODBox parameters on external panels</p>	 Two 3D models of a table with a SWOODBox. The left model shows a white table with a blue SWOODBox. The right model shows a dark wood table with a dark wood SWOODBox. A yellow arrow points from the left model to the right model, indicating the application of parameters to external panels.
<p>SWOODBox origin offset</p>	 A 3D model of a SWOODBox. The box is shown in a perspective view. A yellow arrow points to the bottom-left corner of the box, indicating the origin offset.

Save File by Drag&Drop

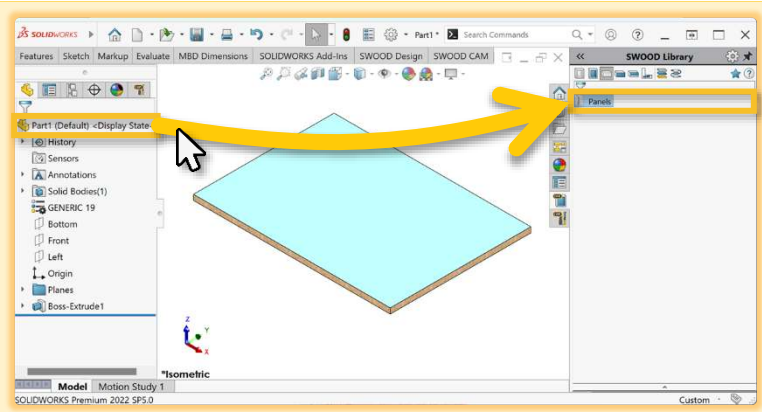

Display of SWOOD Center model parameters

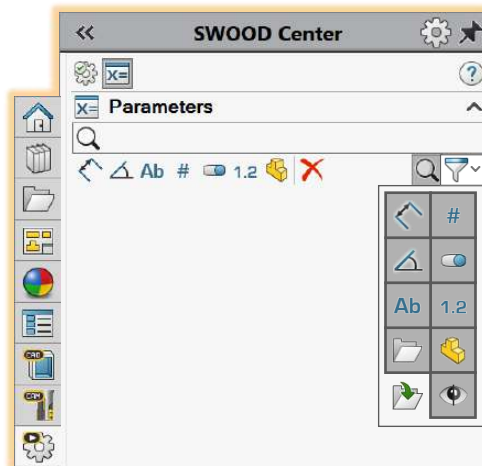

Search for files in libraries



Clickable links in SWOODBox messages

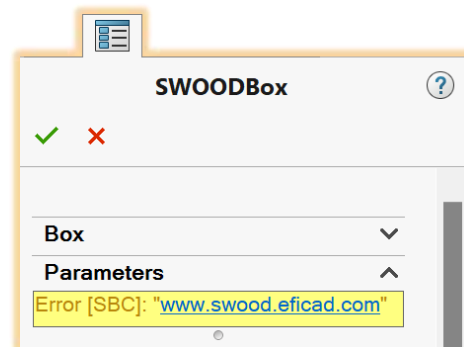

New mathematical script functions

' Recherche du MINIMUM entre deux nombres
 $\text{MinResult} = \text{Min}(A, B)$

' Recherche du MAXIMUM entre deux nombres
 $\text{MaxResult} = \text{Max}(A, B)$

' ARRONDI INFÉRIEUR à un certain nombre de chiffres après la virgule
 $\text{RoundMinResult} = \text{Floor}(A, C)$

' ARRONDI SUPÉRIEUR à un certain nombre de chiffres après la virgule
 $\text{RoundMaxResult} = \text{Ceil}(B, C)$

SWOOD CAM

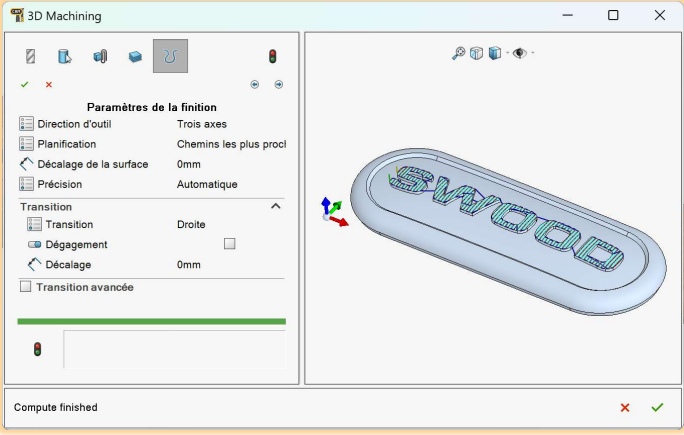
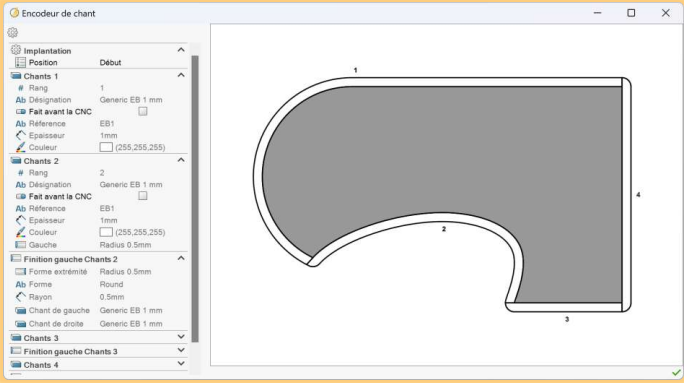
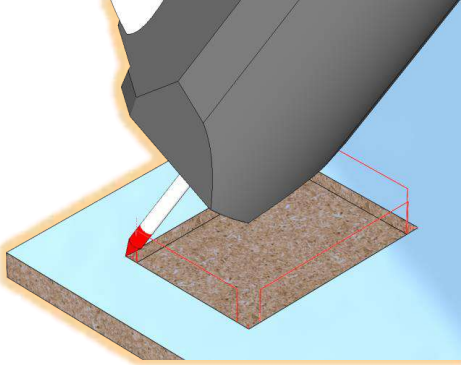
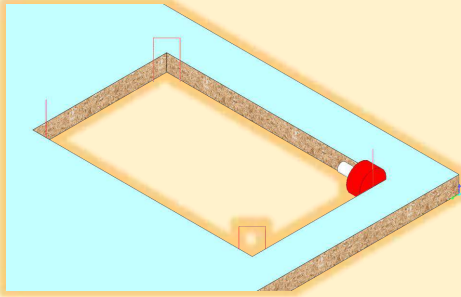
New feature	Description
<p>New 3D Finishing (BETA)</p>	
<p>Edgeband Encoder</p>	
<p>Angle Finishing</p>	
<p>Corner Notching</p>	

Clamex with milling tool

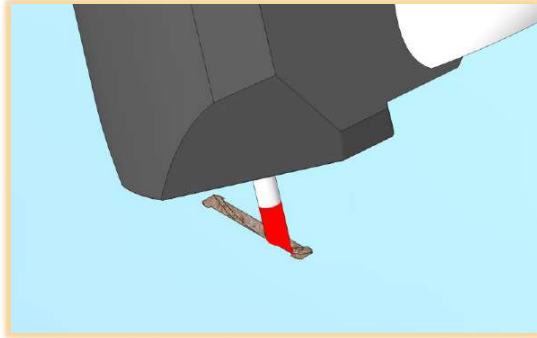

New automatic orientation strategies

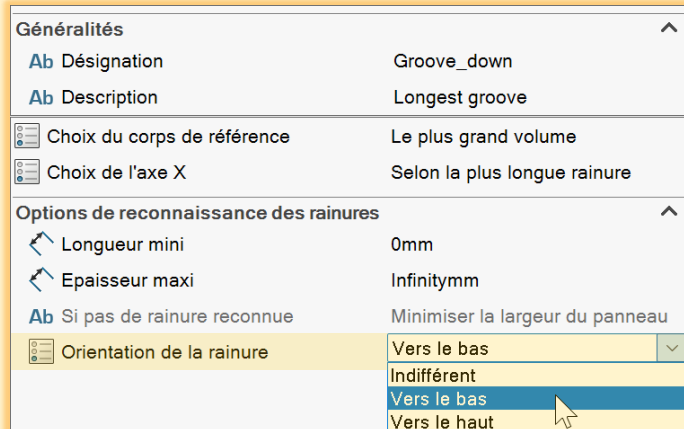

Simplified access to "Tools synchronization" and "CAM Copy"

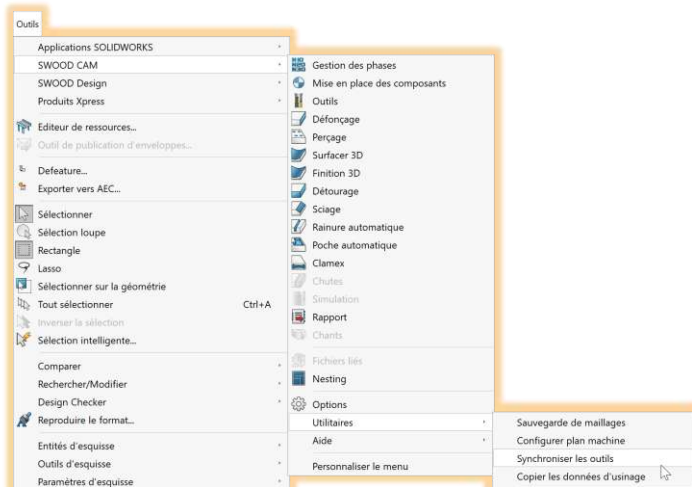

Report option if no machining to be encoded

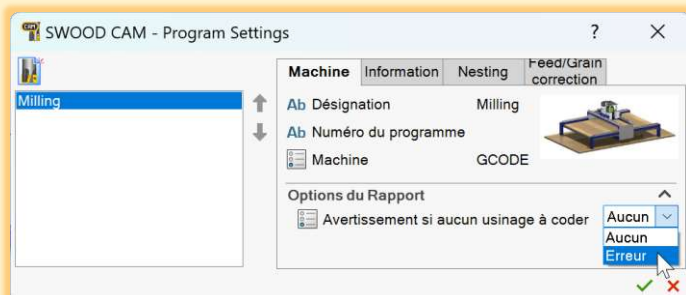

SWOOD Nesting

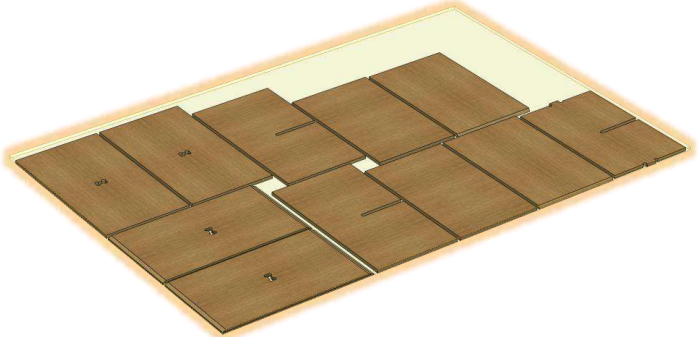
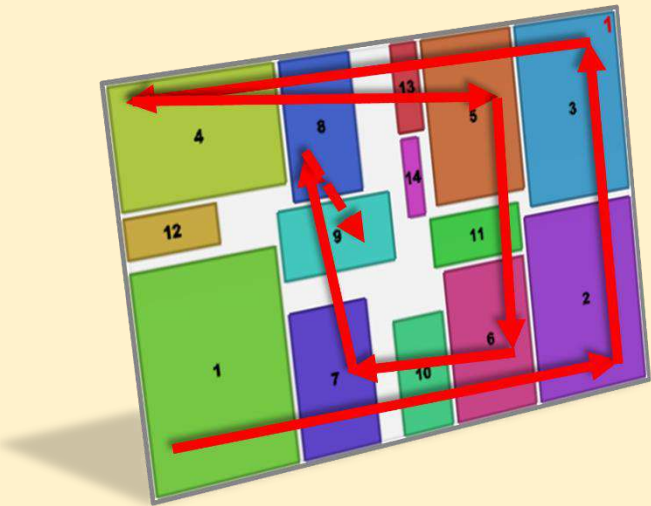
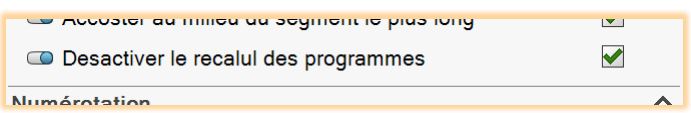
New feature	Description
<p>Ignore grain direction</p>	
<p>Forcing four corners in part types</p>	
<p>Disable program recalculation</p>	

SWOOD Report

New feature	Description
-------------	-------------

System Report

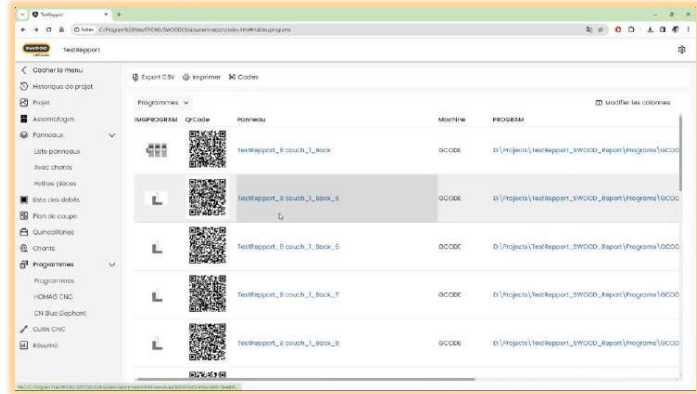

Cutting Pattern

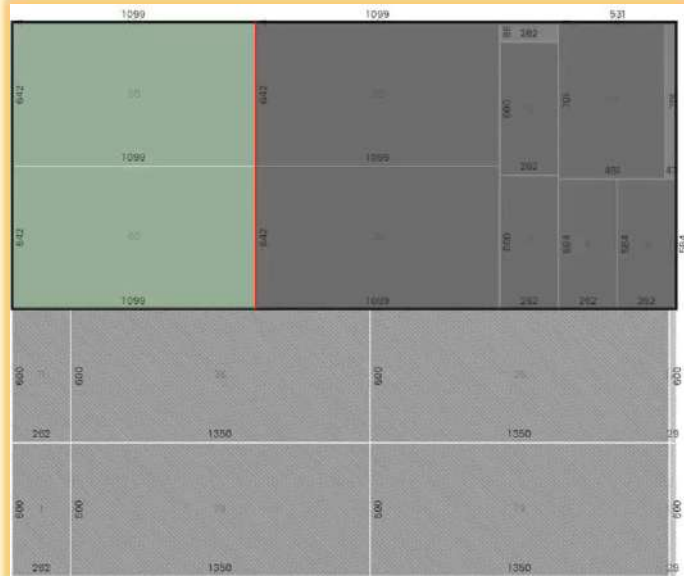

SWOOD Design – Panel Joint

The latest SWOOD Design update introduces an exciting new feature: the creation of interference joints.

Now, users can easily design complex joints, such as miter-cuts, halved-joint and mortise and tenon, by manipulating the intersection of two panels. This innovation makes it possible to customize joints with a variety of adjustable parameters, greatly simplifying structural design and the production of made-to-measure wood parts.

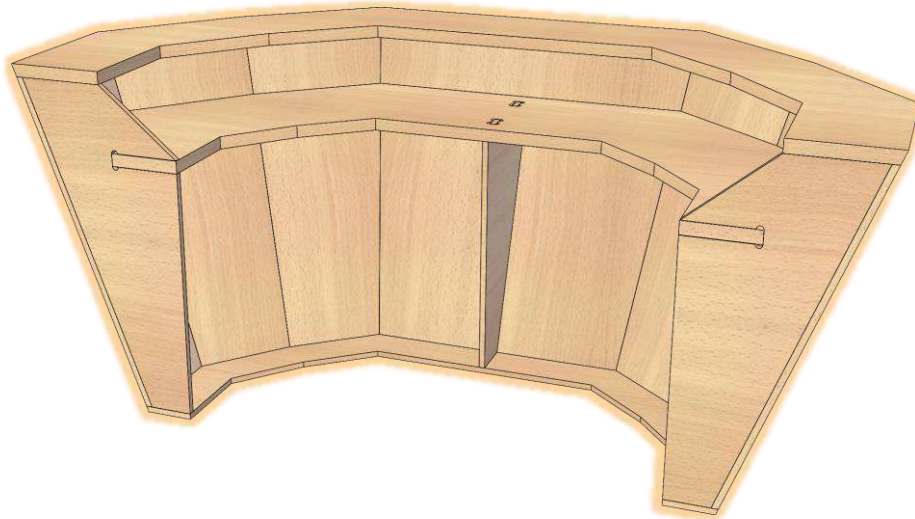

Example of a project using Panel Joints

I. How to use

1. Panel Joint types

There are three types of Panel Joint:





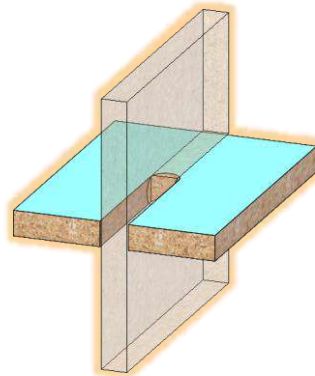

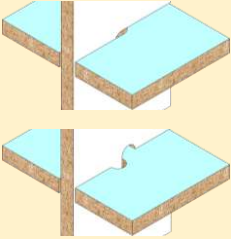

a. The "Halved Joint"

The Halved Joint is a joint between two overlapping wooden parts. The cross-section of each part is halved at the intersection to allow the other to pass through, thus maintaining the continuity of the two parts. SWOOD Design's "Halved Joint" Panel Joint refers to the joint carried out on the edge of the wood parts, rather than on the flat.

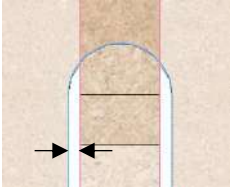

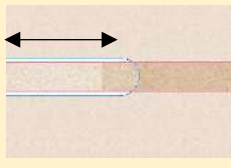

Example of de "Halved Joint"

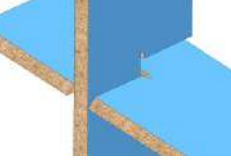
The "Halved Joint" can be defined by the following parameters:

Icon	Name	Effect	Image
	Type	<ul style="list-style-type: none"> • "Classic Halved Joint": The end of the halved Joint is a semicircle the width of the notch. • "Undercut Halved Joint": More elaborate halved Joint which, thanks to its free corners, allows contact between the two inner surfaces. 	
	Offset	Operating clearance between two panels.	
	Reverse the direction	Reverse the position of the joint between the two panels.	
	Tool radius*	<i>* Only for the "Undercut Halved Joint" type.</i> Radius of recess created by corner clearance.	
	Location	Joint position as a percentage of joint width.	
	Use 3 axis machining	Cut the panels so that they can be machined by a 3-axis machine.	



To obtain a "traditional" Halved Joint with straight corners, apply the following parameters:

- A  **"Undercut Halved Joint"** type.
- A  Tool radius of **0mm**.

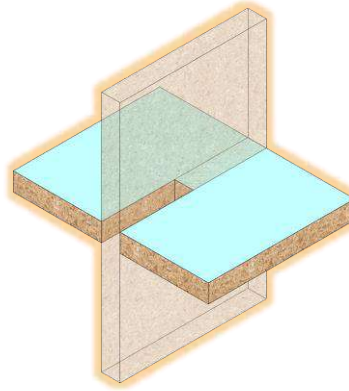

Traditional "Halved Joint" with straight corners





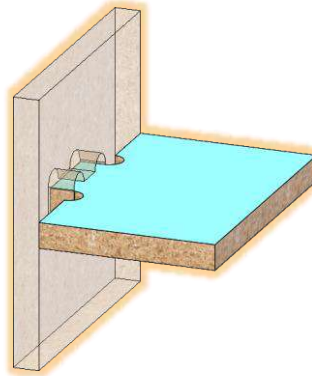

b. The  "Mortise and Tenon"

The "Mortise and Tenon" is a traditional joint used to join two perpendicular wooden parts. The tenon is a rectangular projection cut into the end of one part, while the mortise is a corresponding recess cut into the other part.

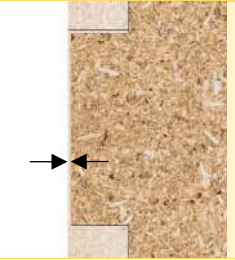

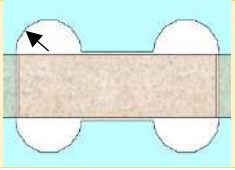
Example of a "Mortise and Tenon" joint

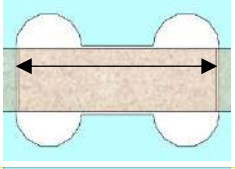
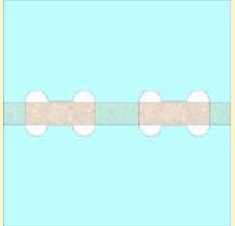
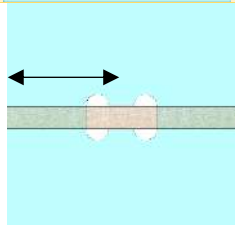
The "Mortise and Tenon" joint can be defined by the following parameters:

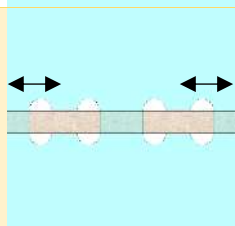
Icon	Name	Effect	Image
	Offset	Operating clearance between two panels.	
	Reverse the direction	Reverse the position of the joint between the two panels.	
	Tool radius	Radius of recess created by corner clearance.	
	Mortise length	Mortise length, without taking the offset (clearance) into account.	
#	Quantity	Number of "Mortise and Tenon" joints across the entire interference between the two panels.	
%	Location*	<i>*Only when quantity equals 1.</i> Joint position as a percentage of joint width.	
	X Offset*	<i>* Only when quantity equals 1.</i> Position of end mortises (on the joint axis).	

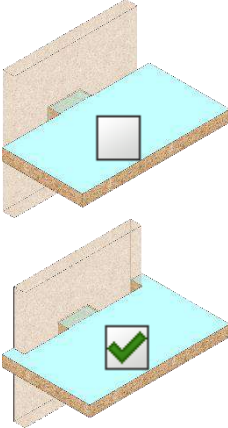
	<p>Use body to compute instead of box</p>	<p><input type="checkbox"/> <u>Unchecked</u>: Cut the tenon panel to match the face of the mortise panel.</p> <p><input checked="" type="checkbox"/> <u>Checked</u>: Cut the tenon panel along the body of the mortise panel.</p>	
---	---	---	---



To obtain a "traditional" Mortise and Tenon joint with straight corners, apply the following parameters:

- A  Tool radius of **0mm**.

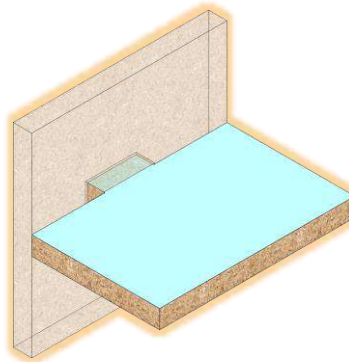

Traditional "Mortise and Tenon" with straight corners

c. The "Panel Cut"

The Panel Cut groups together three separate joints:

- Miter Cut: Saw cut to join two panels along the bisector of their angle, thus avoiding the need for an edgeband on their end.

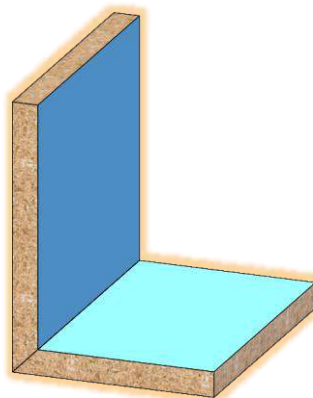

Example of a "Miter cut"

- One cover two: Cuts the panel whose plane has been selected second.

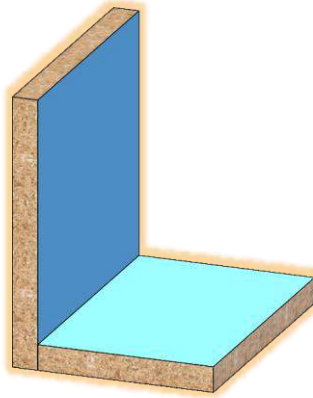

Example of "One cover two"

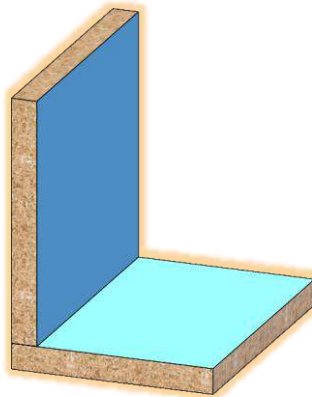

- Two cover one: Cuts the panel whose plane was selected first.



Example of "Two cover one »

The "Panel Cut" can be defined by the following parameters:

Icon	Name	Effect	Image
	Type	<p>"Miter Cut": Cuts the panels along the bisector of the angle of the two planes.</p> <p>"One cover two": Cuts the panel whose plane has been selected second.</p> <p>"Two cover one": Cuts the panel whose plane was selected first.</p>	
	Reverse the direction	Reverse the position of the joint between the two panels.	

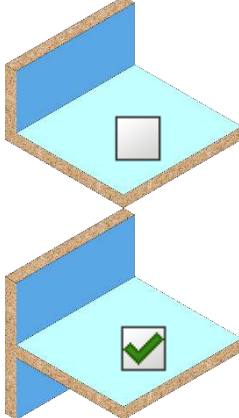
	<p>Internal opening*</p>	<p><i>*Only for "Miter Cut" type.</i></p> <p>Size of the corner opening between the two panels.</p>	
	<p>Do not cut the covering part*</p>	<p><i>* Only for "One cover two" and "Two cover one" types.</i></p> <p>Allows to let the covering part run instead of cutting it off at the end of the other panel.</p>	

2. Interface

a. Creating Panel Joints

In order to create Panel Joints, you must first open a  SolidWorks assembly, then there are several ways to create Panel Joints:

i. From the menu bar

To create Panel Joints from the menu bar, go to:

Tools → SWOOD Design → Panel Joint

This gives you access to all Panel Joints.

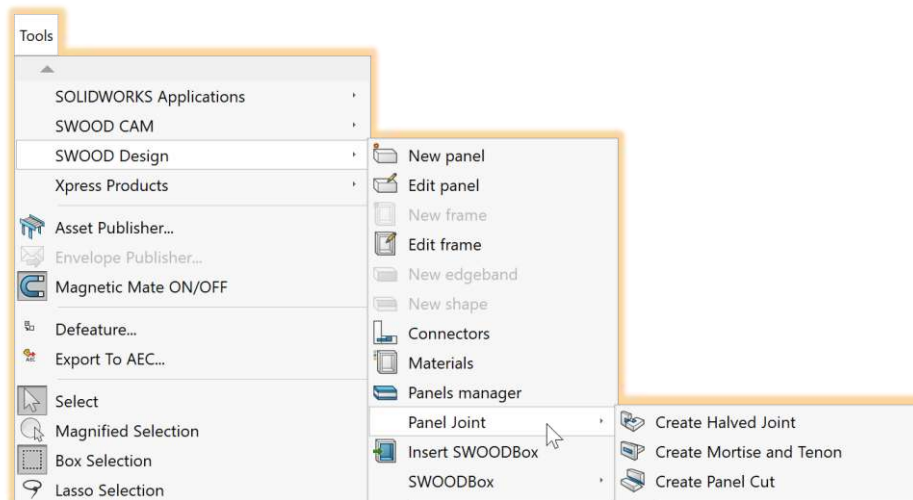

ii. From the CommandManager

SWOOD Design's Command Manager can be integrated with a Flyout toolbar containing the various commands for creating Panel Joints.

To do this, you need to:

1. Right-click on the SWOOD Design CommandManager.
2. Click on "Customize...".

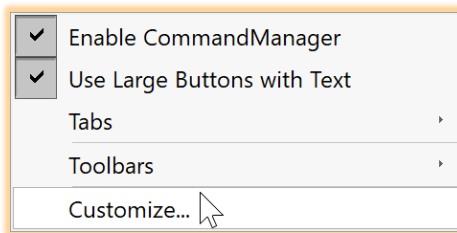

3. Go to the "Commands" tab.

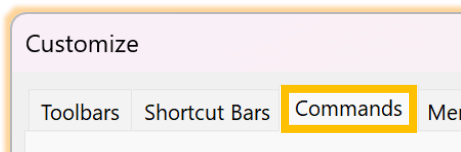

4. In the list of toolbars, click on "Flyout Toolbars" (the second one in the list).

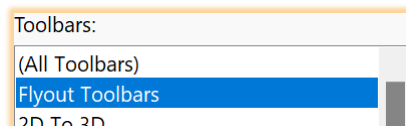

5. In the Buttons section, find the "Panel Joint" command.

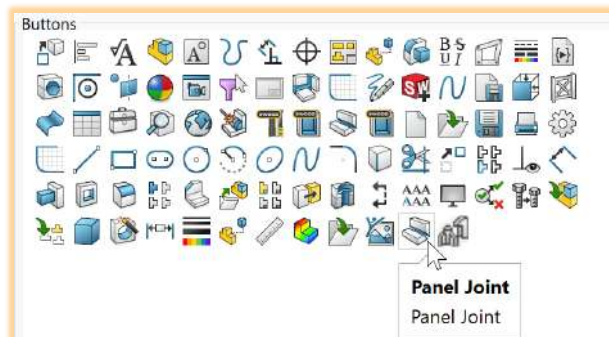

6. Drag and drop the command into the CommandManager.

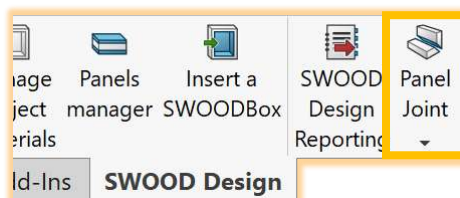

7. Clicking on this Flyout toolbar gives access to all Panel Joints.

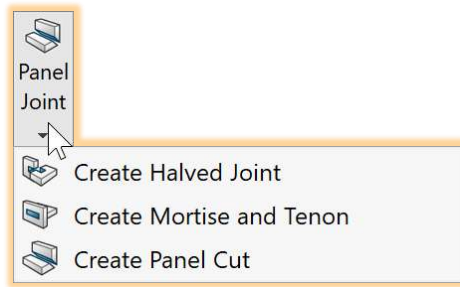



b. Plane selection

Once the Panel Joint has been selected, a PropertyManager appears, named after the Panel Joint.

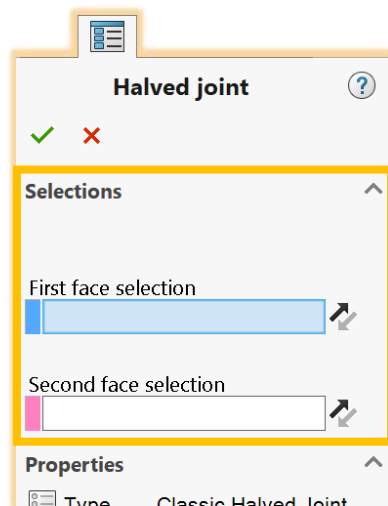
The first parameter section is the plane selection section. In this section, there are two planes to select, which must be the top or bottom face of the panels.



 It is possible to invert the plane selection, using the invert button , for example to switch from the top face to the bottom face.

c. Visualization in the Graphics Area

Once the planes have been selected, a preview of the Panel Joint is shown in the Graphics Area.

The **blue** preview shows the joint for the first panel selected.

The **pink** preview shows the joint for the second panel selected.

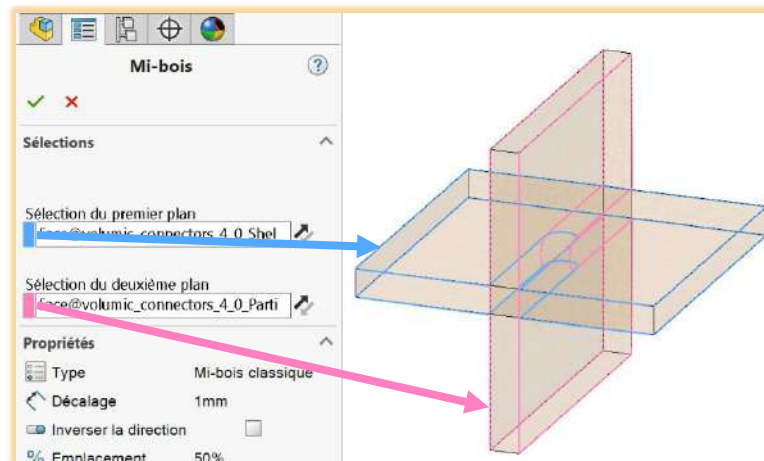

Some joints have arrows to indicate the direction of the joint:

i. The  "Mortise and Tenon"

For the "Mortise and Tenon" joint, the viewing arrow is used to show the direction of the tenon, towards the inside of the panel.

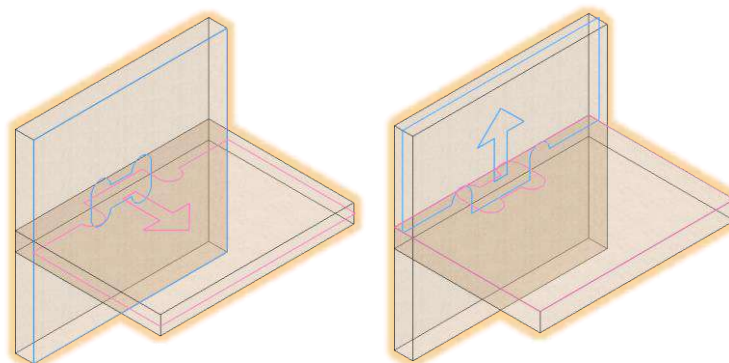

Display arrow for viewing "Mortise and tenon" joint

ii. The  "Panel Cut"

For the "Panel Cut" joint, two arrows are provided to show the cutting direction for all three types of cut.

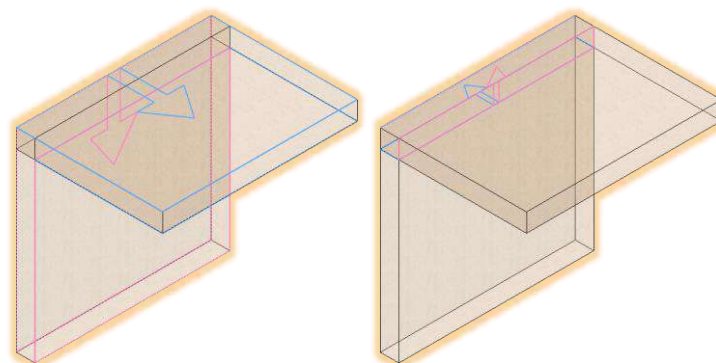

Display arrows for viewing "Miter cut" type

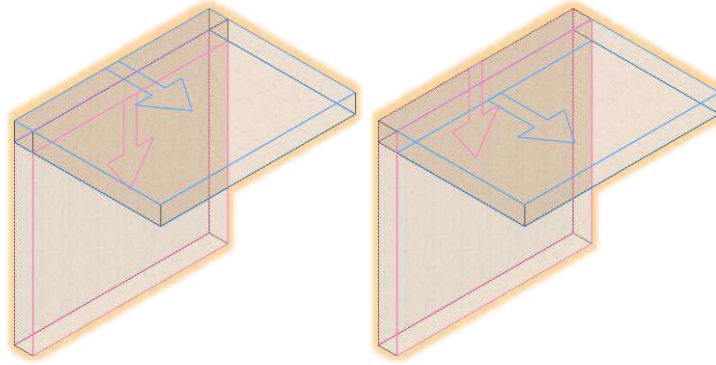

Display arrows for "One covers two" and "Two covers one" types

d. Parent and child functions

Once the Panel Joint assembly has been created and the PropertyManager validated, several SolidWorks functions are created in the FeatureManager Design Tree:

i. Assembly level

At SolidWorks  assembly level, Panel Joint functions are located at the very bottom of the FeatureManager Design Tree.



When you edit this function, you'll find all the Panel Joint parameters previously presented.

ii. Part level

At SolidWorks  part level, Panel Joint functions are located at the very bottom of the FeatureManager design tree.



When editing this function, you can select the "Action body" or "Action bodies". This allows you to define which body(ies) will be used as a reference when applying the Panel Joint.

II. Explanatory video

To get a better idea of how to use this feature, take a look at the following video:

[Panel Joint](#)

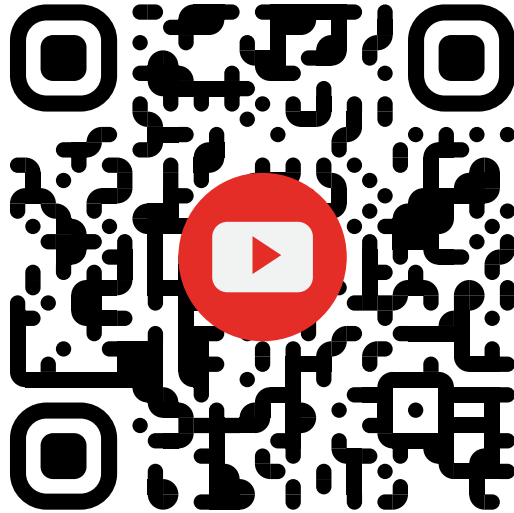

SWOOD Design – SWOODBox parameters on external panels

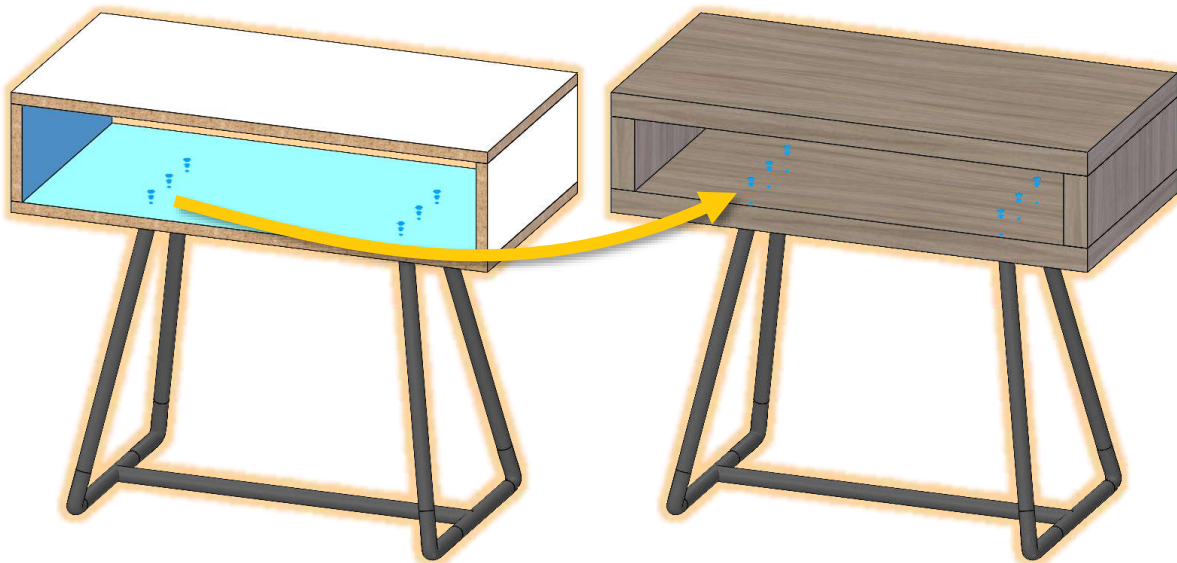

With this SWOOD Design update, users now benefit from an advanced feature that dynamically adjusts the behavior of the SWOODBox using the dimensions of the surrounding panels. This technical advance opens up new possibilities for customization and efficiency, enabling precise, automated adaptation of your wood projects. Thanks to this intelligent integration, designing wood structures and elements becomes more intuitive, faster and less error-prone, taking design automation to the next level.



Example of a project where the thickness of the frame panel is used to position the top screws of the SWOODBox.

I. How to use

To access these dimensions on the context outside the SWOODBox, you need to edit a SWOODBox. To do this, you need to:

- Go to the SWOOD library .
- Go to the SWOODBox library .
- Right-click on a SWOODBox, then click on "Edit".

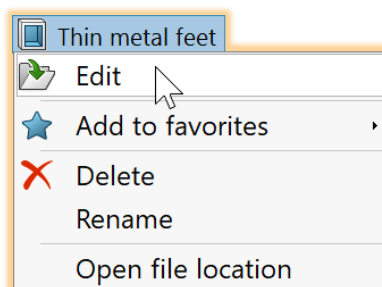

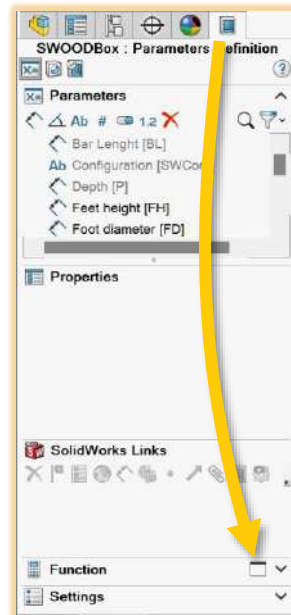

- Once the assembly is open, click on the "SWOODBox" PropertyManager.
- Open script window

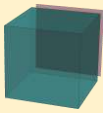
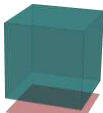

In the list of SWOODBox  context variables, there are:

- 6 parameters for outer panel thicknesses:

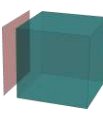
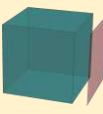
Panel	Parameter's name	Alias
Back 	Back thickness	SBBKT
Bottom 	Bottom thickness	SBTT
Front 	Front thickness	SBFT
Left 	Left thickness	SBLT
Right 	Right thickness	SBRT

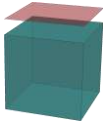
<p>Top </p>	<p>Top thickness</p>	<p>SBTT</p>
--	----------------------	--------------------

- 6 box offset parameters:

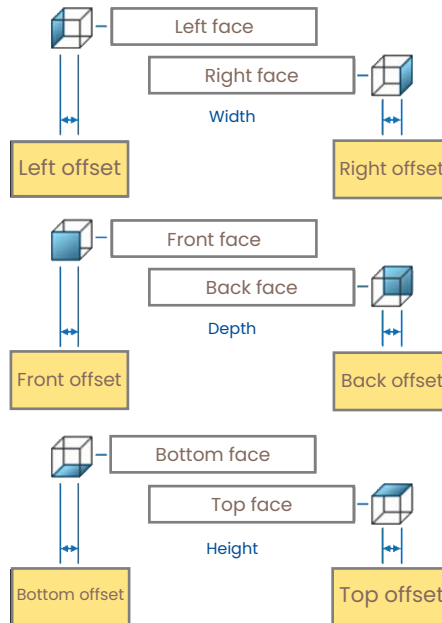

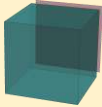
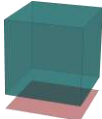
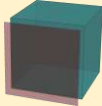
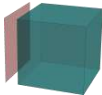
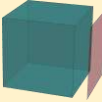
Offset	Parameter's name	Alias
<p>Back offset </p>	<p>Back gap</p>	<p>SBKBO</p>
<p>Bottom offset </p>	<p>Bottom gap</p>	<p>SBBTO</p>
<p>Front offset </p>	<p>Front gap</p>	<p>SBFO</p>
<p>Left offset </p>	<p>Left gap</p>	<p>SBLO</p>
<p>Right offset </p>	<p>Right gap</p>	<p>SBRO</p>

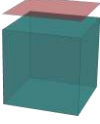
Top offset 	Top gap	SBTO
--	---------	-------------

 **Warning:** These 12 context variables are read-only, meaning that they can only be read and not controlled via the script.

II. Explanatory video

To get a better idea of how to use this feature, take a look at the following video:

[SWOODBox parameters on external panels](#)



SWOOD Design – SWOODBox origin offset

SWOOD Design version 2024 introduces a new feature that enhances design capabilities: the three-dimensional offset of a SWOODBox along the X, Y and Z axes. Thanks to the introduction of new parameters, users can now precisely adjust the position of a SWOODBox in relation to its insertion volume, without resorting to offset planes. This innovation opens the door to the creation of more complex, customized SWOODBox configurations, simplifying the design process and offering greater flexibility in the spatial adjustment of your project elements.

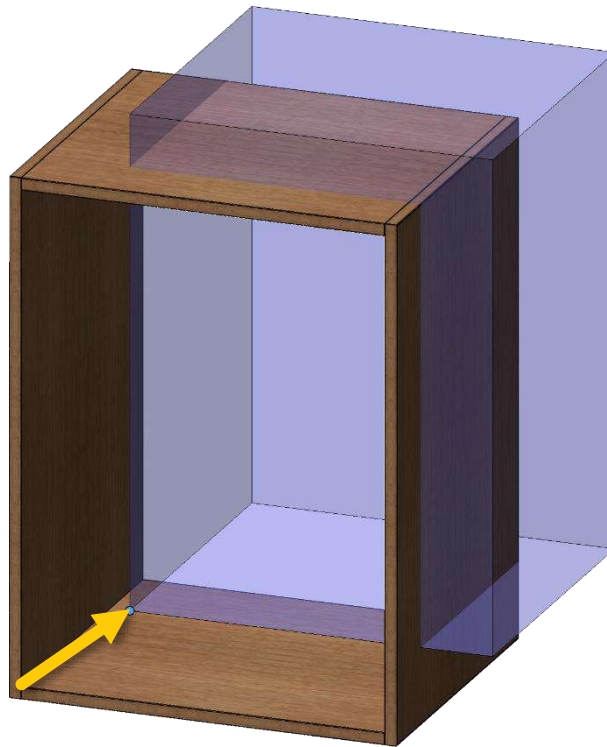



Example of SWOODBox origin offset in X, Y and Z



I. How to use

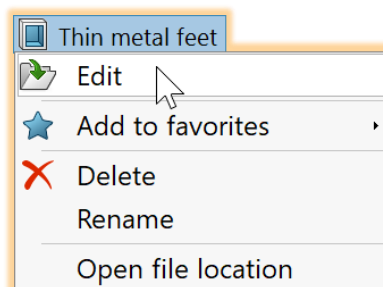

1. Access to the parameter

To use SWOODBox's original offset, it is necessary first to:

- Go to the SWOOD library .
- Go to the SWOODBox library .
- Right-click on a SWOODBox, then click on "Edit".



- Go to the SWOODBox PropertyManager .
- Open the script window .

Among the SWOODBox "  Object" parameters is the new "  Origin offset" parameter, alias "ORIGINOFFSET".

2. Use of the parameter

Afin d'appliquer des décalages à l'origine selon les axes X, Y, ou Z de la SWOODBox, il faut écrire le script suivant :

Script	Effect
ORIGINOFFSET. X = 100	SWOODBox X-axis origin offset of 100mm
ORIGINOFFSET. Y = 100	SWOODBox Y-axis origin offset of 100mm
ORIGINOFFSET. Z = 100	SWOODBox Z-axis origin offset of 100mm

SWOOD Design – Save File by Drag&Drop

This new SWOOD Design feature makes it easy to drag and drop a 3D model opened in SOLIDWORKS, directly into the SWOOD Design library. It automatically saves new designs, creates copies of existing designs and adds shortcuts, making file management quick and easy.

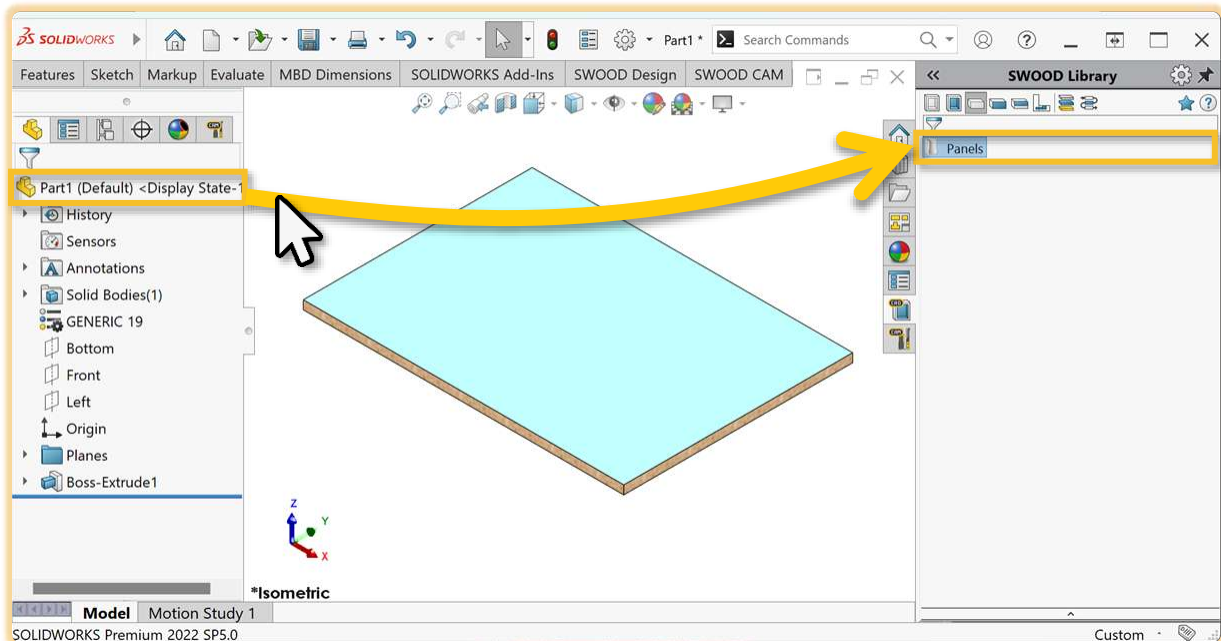

Example of file saving using drag & drop

I. How to use

1. Drag & drop

The saving action takes place as follows:





1. Click on the name of the part or assembly in the FeatureManager Design Tree.
2. Hold click and drag cursor to target SWOOD Design library.
3. Release the item in a folder in the target SWOOD Design library.

2. Use cases

This feature can be used in three distinct situations:

- If the SolidWorks file is not saved on the computer, drag & drop will save the file in the SWOOD Design library.
- If the SolidWorks file is already saved on the computer, drag & drop will copy the file to the SWOOD Design library.
- If the SolidWorks file is already saved on the computer, drag & drop combined with the "SHIFT" key will create a link in the SWOOD Design library to the original file.

The following table summarizes the use cases for the new feature:

Case	Already saved?	Pressed key	Consequence
New file 	No	∅	The file will be saved in the SWOOD Design library.
Copy 	Yes	∅	A copy of the file will be saved in the SWOOD Design library.
Link 	Yes	 SHIFT	A link will be created in the SWOOD Design library to the existing file.

Each case has the following specificities:

e. *New file* 

If you wish to save a new file that has not yet been saved on the computer, and the file type can be saved in the library, a save window will open at the location selected at the time of deposit.



In this window, you can:

- Specify file name and save.
In this case, the file will be saved in the location selected at the time of deposit.
Change the save location, specify a file name and save.
In this case, the file will be saved in the new location.

 If the new location is not in a library folder, the directory of the saved file is added to the library.

f. *Copy* 

If the file is already saved on the computer, drag & drop creates a copy of the current file in the location selected at the time of deposit.

-  The file must be saved before creating the copy.
-  Copied file does not open automatically.

g. *Link* 

If the **SHIFT** key is held down during deposit, a link to the file directory is created in the library.

 If the link already exists in the library, the node corresponding to the moved document is displayed in the tree.

3. Restrictions

The drag&drop saving feature observes a few restrictions between SolidWorks file types and SWOOD Design libraries:

- Parts can only be saved in the panel library.
- Assemblies can only be saved in the Frame library or the SWOODBox library.
- Drawings cannot be saved in any SWOOD Design library.

The following diagram summarizes these restrictions:

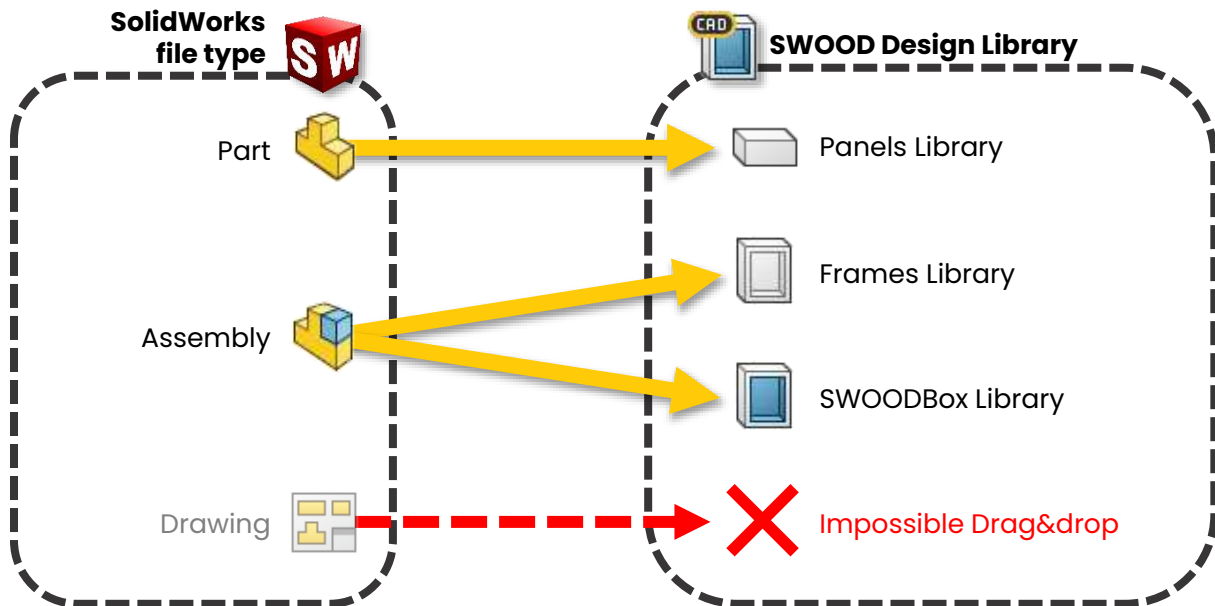

SWOOD Design – Display of SWOOD Center model parameters

A new feature in SWOOD Design 2024 concerns the editing of SWOOD Center models. As with SWOODBoxes in 2023, a set of tools for displaying model parameters will facilitate, secure and accelerate model creation.

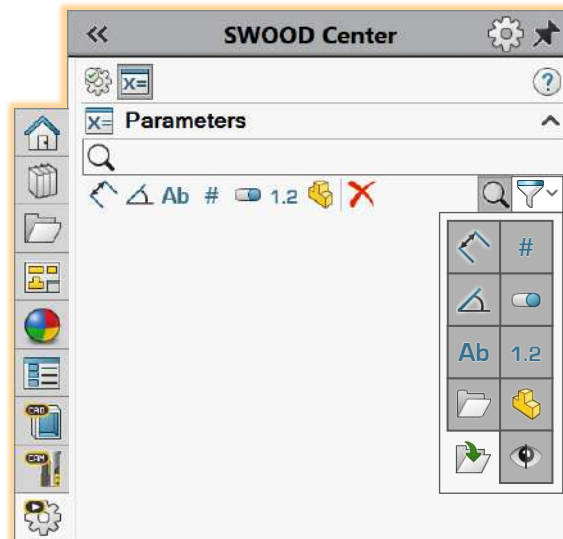

SWOOD Center model parameters interface

I. How to use

To view the new SWOOD Center model parameters, simply create or modify an existing SWOOD Center model.

1. Search bar

To access the search bar, simply click on the  magnifying glass icon in the parameter's toolbar. It will open the search bar above.









- **Search is not case-sensitive.** For example, a search for "Oo" may display words with "oo" or "OO".
- **Search is inclusive.** For example, a search for "oo" might return "Groove".
- **Search is active in variable names, descriptions, aliases and categories.**

2. Filters

It is possible to display certain parameters according to some of their properties.

a. Parameter types

Filters can be applied to the following parameters:  Distance,  Integer,  Angle,  Boolean,  String,  Decimal and  Object.

b. Exposure

If the "Exposed" filter is  unchecked, only exposed parameters are shown in the list.

3. Folder organization

Parameters with a category are now placed in a folder with the name of the category in the list of parameters.



It is possible to assign a category to a parameter simply by dragging it into a folder.

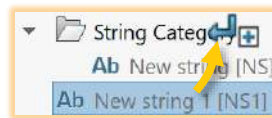

This folder organization can be deactivated by clicking on the  "Show/Hide Repository" filter.

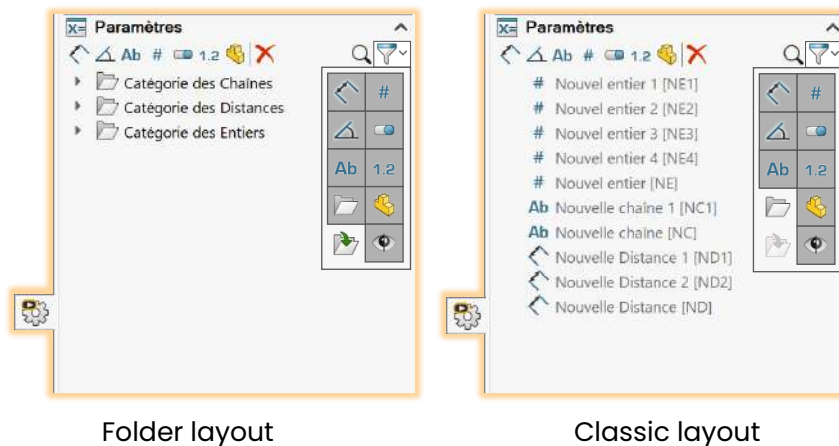

If folders are visible, you can open all folders at once by clicking on the  "Open/Close Repository" filter.

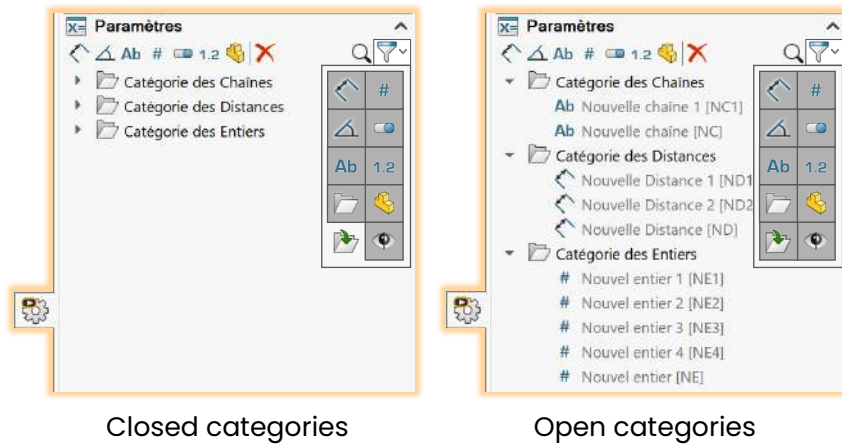

Closed categories

Open categories

SWOOD Design – Search for files in libraries

With SWOOD 2024, there is a significant improvement in the search algorithm for SWOOD Design libraries. This improvement is particularly relevant for companies with SWOOD Design libraries containing many elements.



Indeed, with this new algorithm, the search takes **4x** less time to complete.

From now on, results will be displayed as a list of items matching the search, rather than in a sub-folder structure.

I. How it works

Old search algorithm	New SWOOD 2024 search algorithm

II. Explanatory video

To get a better idea of how to use this feature, take a look at the following video:

[Search for files in libraries](#)



SWOOD Design – Clickable links in SWOODBox messages

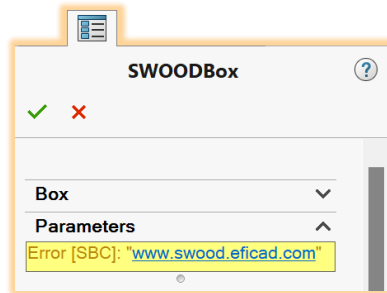

This new feature has been created to allow users to click on hyperlinks when they appear in SWOODBox messages. This can be particularly useful for directing the user to the catalog of a hardware supplier used in the SWOODBox.





Example of SWOODBox editing with a clickable link in a SWOODBox message

I. How to use

In order to create clickable links in SWOODBox messages, you have to:

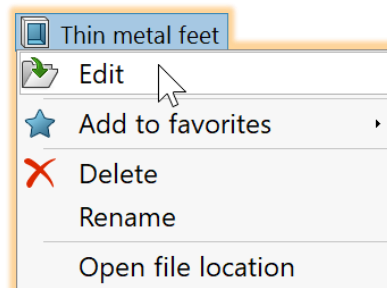
- Go to the SWOOD library .
- Go to the SWOODBox library .
- Right-click on a SWOODBox, then click on "Edit".



- Once the assembly is open, click on the "SWOODBox" PropertyManager.
- Open the script window .

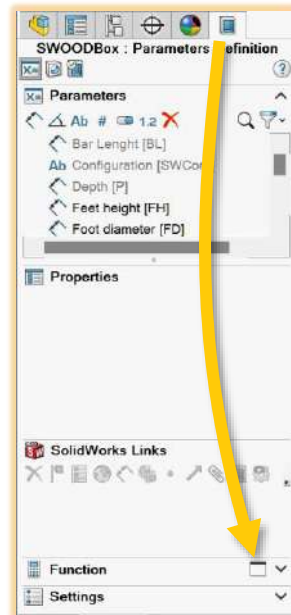

In your SWOODBox script, you can include a message containing an URL.

```

L=SBL
H=SBH
P=SBP

MSG = "https://eficad.com/"

```

This link can be clicked directly in the SWOODBox "Test Mode" and also when editing the SWOODBox once it has been inserted.

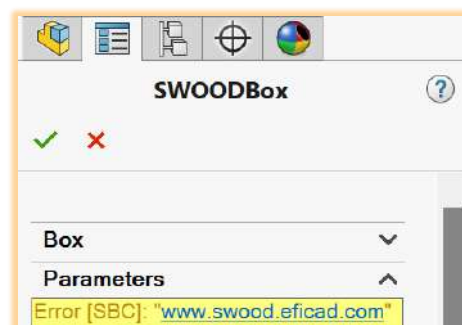
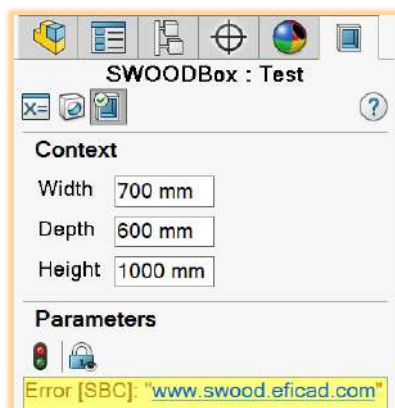

SWOOD Design – New mathematical script functions

SWOOD Design 2024 integrates four new scripting functions that can be very useful for SWOODBox, Connectors and SWOOD Center models.

The **Min(A, B)** function compares the two values A and B and returns the **minimum**.

The **Max(A, B)** function compares two values, A and B, and returns the **maximum**.

The **Floor(A, C)** function is used to **round down** A to C decimal places.

The **Ceil(B, C)** function is used to **round up** B to C decimal places.

```
' Finding the MINIMUM between two numbers
MinResult = Min(A, B)

' Finding the MAXIMUM between two numbers
MaxResult = Max(A, B)



' LOWER ROUNDING to a certain number of decimal places
RoundMinResult = Floor(A, C)

' UPPER ROUNDING to a certain number of decimal places
RoundMaxResult = Ceil(B, C)
```

Script example using the new mathematical functions

I. How to use

In order to use the new mathematical script functions, you need to edit the script:

-  Of a SWOODBox.
-  Of a connector.
-  Of a SWOOD Center model.

1. Minimum and Maximum

The minimum (Min) and maximum (Max) functions compare two numbers and give either the minimum or the maximum between these two values.

 **Warning:** The minimum and maximum functions can be used to compare only **two** numerical parameters.

 **Tip:** To compare more than just two numbers in a minimum or maximum function, you can interlock the functions. For example, to find out the minimum between the numerical parameters A, B and C, simply write:

$$\mathbf{Result = Min(Min(A, B), C)}$$

2. Top and bottom rounding

The "Floor" and "Ceil" rounding functions are used to round a numerical parameter to a certain number of decimal places.

For example, if you take the decimal number "1.2345" and want to round it to three decimal places:

The formula **Floor(1,2345, 3)** returns **1,234**

The formula **Ceil(1,2345, 3)** returns **1,235**

SWOOD CAM – New 3D Finishing (BETA)

SWOOD CAM version 2024 revolutionizes its 3D machining management with the introduction of its new 3D Finishing machining. This major advance, features a significant improvement in algorithmic stability, surpassing the performance of previous finishing operations. It is complemented by a completely redesigned operation editing interface for maximum intuitiveness, offering users unprecedented flexibility thanks to an expanded range of selections and options. What's more, this feature eliminates the need to create stitched surfaces thanks to advanced 3D object recognition, considerably simplifying the machining process. This innovation represents a giant step forward in the optimization and customization of 3D machining, guaranteeing high-quality finishes with enhanced efficiency and ease of use.

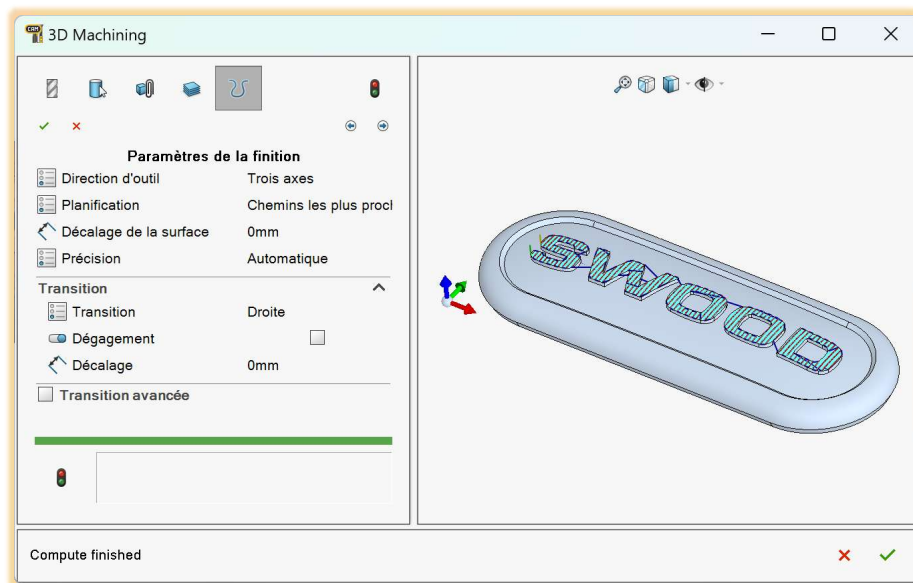

New 3D Finishing interface

I. How to use

To use the new 3D finishing, you no longer need to create  Knit surfaces on the surfaces you wish to machine. From now on, no selection is required to create a new 3D finishing.

1. Access to the new 3D finishing

To access the new 3D finishing interface, simply go to the SolidWorks menu bar:

Tools → SWOOD CAM →  3D Finishing



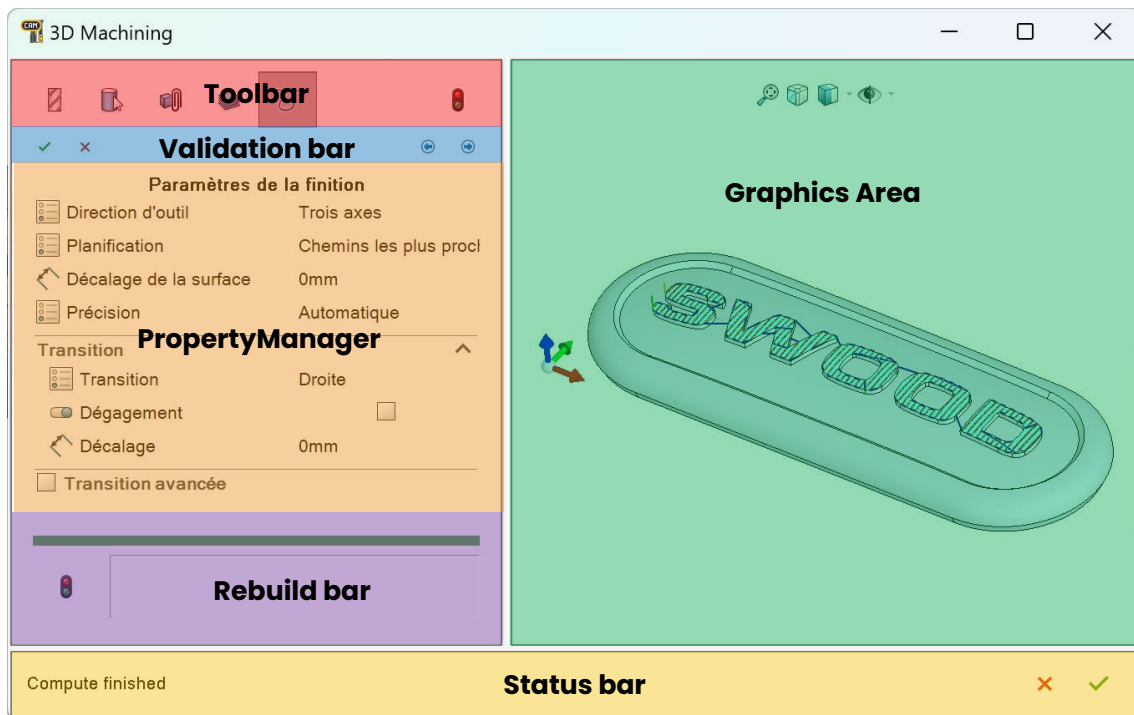

2. Interface



The new 3D finishing window is divided into 6 sections:



a. Toolbar

The toolbar of the new 3D finishing window contains the following commands:





Icon	Command name	Description
	Technology Parameters	Defines the machining and technology parameters of the operation. These include the operation name as it will appear in the milling phase, tool selection and cutting parameters. It is also possible to choose the operation's technology parameters and manage the Z axis movements.
	Face Selection	Selects the faces to be machined and the faces to protect. By default, the entire 3D model is selected. It is also possible to select only some of the model's faces.
	Constraints	Defines operation reference planes and their offsets, such as Z security, Z approach, maximum and minimum machining altitude planes. Use sketches to define specific areas for machining, inclusive or exclusive.
	Slicing Parameters	Defines parameters for slicing the operation, such as slicing direction. Also defines slice adaptability to the

		curvature of the 3D model. In this section, it is also possible to define pass spacing.
	Finishing Parameters	Defines the operation's finishing parameters, such as CNC type or selection of transition type between passes.
	Rebuild	Recalculate operation according to last parameter modification.

When a command is clicked, the PropertyManager adapts to the command and presents the parameters of the section.

b. Validation bar

The validation bar contains the following commands:

<i>Icon</i>	<i>Command name</i>	<i>Description</i>
	Operation Validation	Validates parameters and creates a machining operation.
	Operation Cancel	Does not take machining parameter modifications into account. If this is the first edition of the operation, it is not created; if it is an edition of an existing operation, the parameter modification will not be taken into account.
	Previous Section	Returns to previous section.
	Next Section	Skip to next section.

c. PropertyManager

The parameters displayed in the PropertyManager depend on the section selected in the toolbar.

d. Rebuild bar

The rebuild bar is a visual aid to help you see how far along you are in rebuilding the operation, since modifying parameters alone is not enough to update the operation.

A **green** rebuild bar means that the model has been successfully rebuilt according to the latest parameter modifications.

A blue rebuild bar means that the model has not yet been rebuilt.

e. Status bar

The status bar displays messages appropriate to the state of the model and its rebuilding.







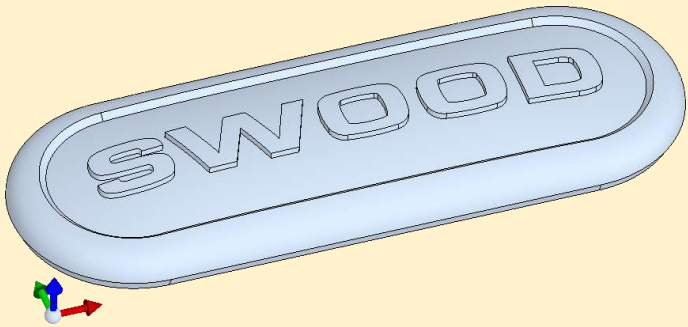
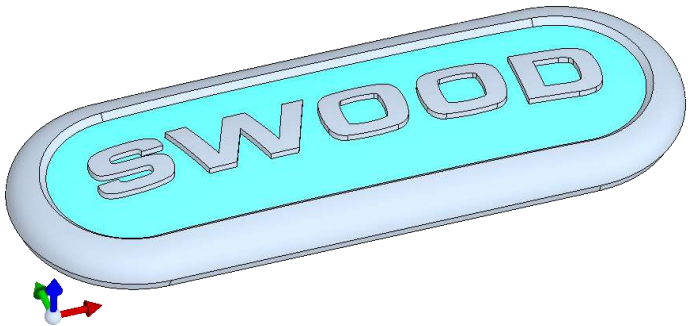
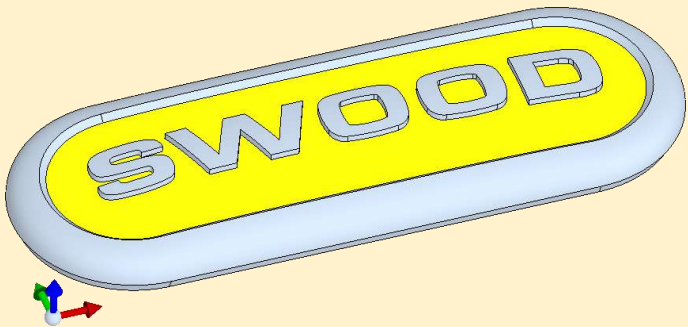











f. Graphics Area

The graphics area displays and interacts with the 3D model, especially when selecting surfaces to be machined, protected or excluded.

The 3D model is displayed without texture, with its origins defined in the machining phase.

Configuration	Image
Sans sélection	
Surfaces usinées (en bleu ciel)	
Surfaces protégées (en jaune)	

The Graphics Area features a Heads-up View Toolbar, with the following commands:

Icon	Command name	Description
	Zoom to fit	Zooms to all visible items.
	View Selector	Choose between standard and non-standard display orientations.
	Display Style	Displays a flyout where you can change the display style for the active view:  Shaded With Edges,  Shaded,  Hidden Lines Removed,  Hidden Lines Visible,  Wireframe, Mesh with fins, Fins.
	Hide / Show All Types	Controls the visibility of all types:  Part,  OP0,  Selected Faces,  Reference Planes,  Trajectory,  Stock,  Slicing,  Protected Faces,  Volumic Constraints.

II. Explanatory video

To get a better idea of how to use this feature, take a look at the following video:

[New 3D Finishing \(BETA\)](#)

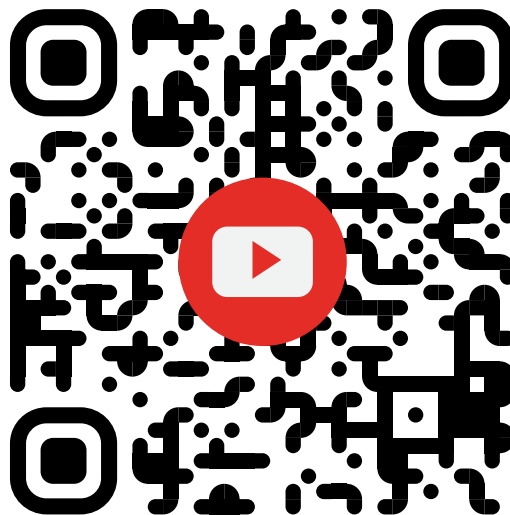

SWOOD CAM – Edgeband Encoder

The latest version of SWOOD CAM introduces a feature that enables automatic  edgeband application directly from the machine, thanks to sophisticated integration in the program code. Designed specifically to work with B-SOLID and WOODWOP post-processors dedicated to this task, this advance offers a solution for automating and simplifying the edgeband application process. This enhancement promises not only to increase manufacturing efficiency, but also to optimize finishing quality. To take full advantage of this feature and transform your production, we recommend that you consult your SWOOD reseller.

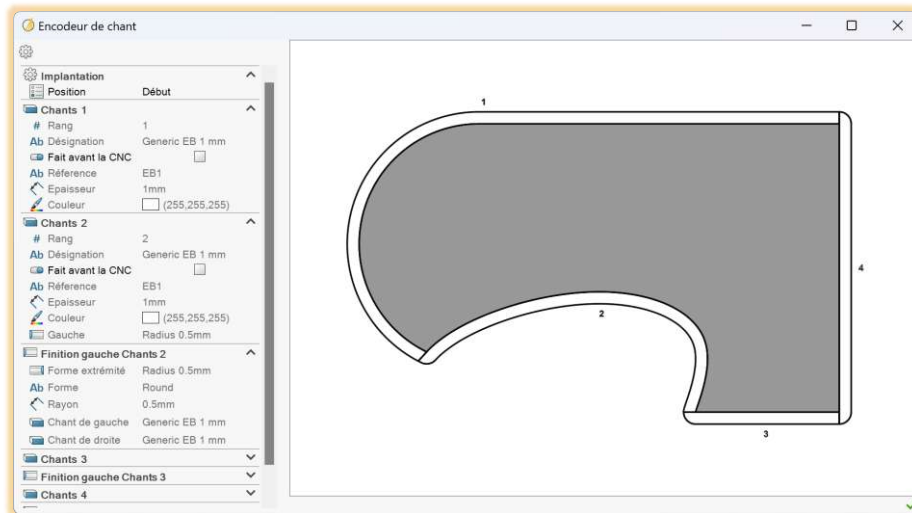

Edgeband encoder window interface





I. How to use

 **Warning:** Edgeband encoder feature can only be used with B-SOLID or WOODWOP post-processors specifically configured for this purpose.

 **Warning:** To use the edgeband encoder feature, SWOOD CAM and SWOOD Design must be activated.

1. Edgeband encoding application

To apply an edgeband encoding to a SWOOD panel, several steps are required:

1. Open a  SWOOD panel in SolidWorks.
2. Apply one or more  SWOOD edgebands.
3. Create a  milling phase with a compatible post-processor and define  origins.
4. Click on the "Edgebands" command, available from the SolidWorks menu bar:

Tools → SWOOD CAM →  Edgebands

Two new elements can be seen in the milling phase:

-  Inserting code into the program.
- A new machining called "Edgebands"



2. Main window



There is no need to edit edgebands for every part. Once they've been set up correctly, there's no need to modify them for future projects.

To access the main edgeband editing window, simply right-click and select "Edit", or double-click on one of the two "edgeband" commands in the milling phase.

The main edgeband editing window is divided into 3 sections:

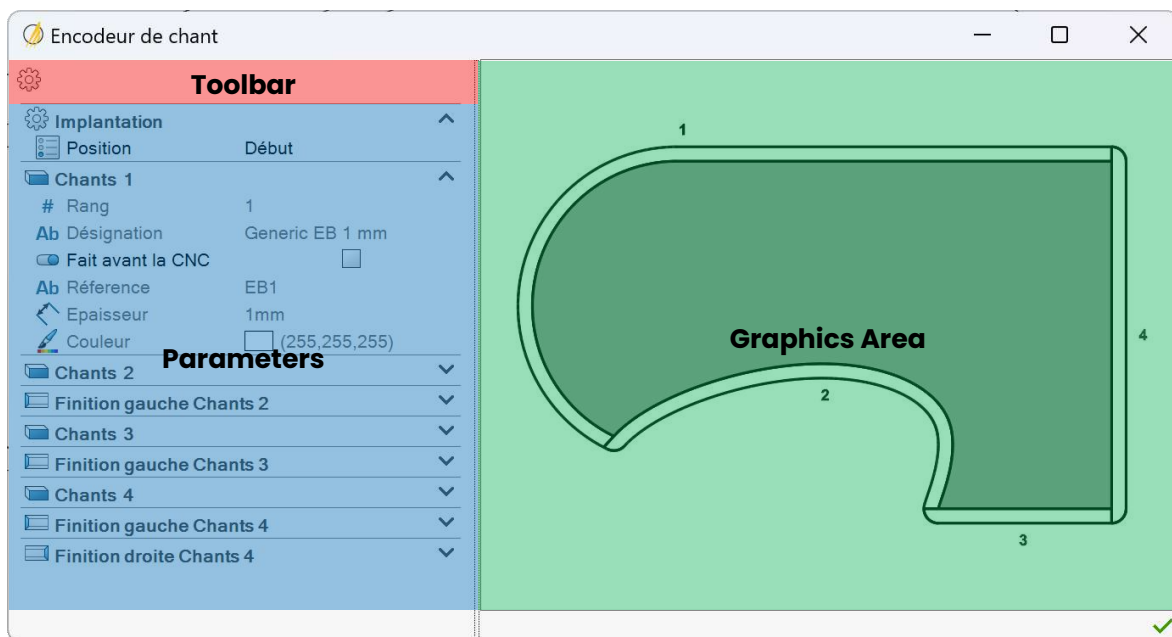

a. Toolbar

The toolbar of the main edgeband editing window contains just one command: the  edgeband encoding parameters.

b. Parameters

The edgeband parameters in this section depend on the edgeband applied to the panel.

The first parameter in the list is always "Positioning". This parameter allows you to choose whether you wish to encode edgebands before or after machining.

i.  Edgebands parameters

- The "# Rank" parameter defines the position of the edgeband in relation to the others. The order of the edgebands in the list displays the most "covered" edgebands first, followed by the "covering" edgebands.
- The "Done before CNC" parameter is used to exclude this edgeband from encoding, as it was done before the CNC.

 **Warning:** Excluding a "covering" edgeband will exclude all covered edgebands.

 **Tip:** The "Done before CNC" parameter can be set directly in the edgebands library, so that it is automatically checked each time it is used.

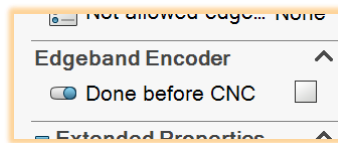

- The other parameters are informative and cannot be modified, as they have already been defined in the Edgebands Library.

ii. Edgeband  finishing parameters (left or right)

Left and right edgeband finishing parameters are informative and cannot be modified, as they have already been defined in the Edgebands Library.

c. *Graphics Area*

The Graphics Area shows the panel in top view from its program origin.

Edgebands are shown thicker, so that they can be easily located and overlaps clearly seen.



The Graphics Area can be zoomed in and out to highlight certain areas of the panel.

When an edgeband is clicked in the Graphics Area, its row number turns red and its edgeband parameters are highlighted in the Parameters section.

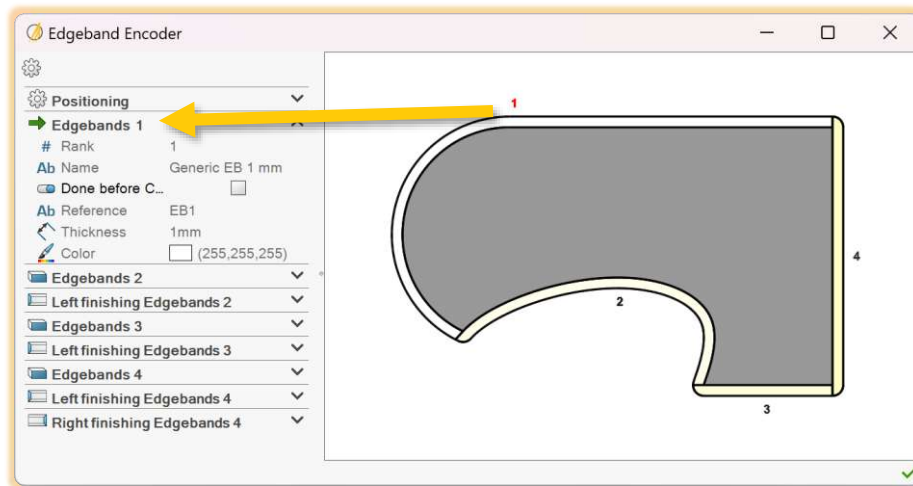





3. Edgeband encoding parameters















To access the edgeband encoding parameters, click on the single toolbar command in the main edgeband editing window.







a. Global settings (*B-SOLID* and *WOODWOP*)

The global settings include the following parameters:

Icon	Parameter name	Description
Configuration		
	Automatic order of edgeband gluing	Allows the software to automatically reorder edgebands to optimize application and minimize tool changes.
	Use edgeband reference	Uses the edgeband reference in the encoding, as defined in the edgeband library.
	Default insertion location	Defines whether the code is inserted at the beginning or at the end.
Graphic display		
	Enable real thickness	Displays edgebands at their actual thickness.
1.2	Zoom speed	Defines zoom speed. The higher the value, the faster the zoom.

b. WOODWOP settings

Icon	Parameter name	Description
Edgeband encoder parameters		
	Only on right angle	Separates edgeband  trimming (Bündigfräsen) into several operations when the angle of intersection of two edgebands is different than 90°.
	Enable blowing	Activates  blowing operation (Abblasen)
	Combine saw round corner	Allows the same aggregate to be used for corner finishing. Also modifies the order of operations to optimize machine movements.
	Enable stop	Adds a stop between edgeband  trimming and  gluing
Macro		
	Right contouring	Adds a specific macro for right contouring all around the part.
	Blow	Adds a specific macro for blowing.
	Saw	Adds a specific macro for the sawing operation.
	Right finishing	Adds a specific macro for the right finishing operation, when performed by contouring with a milling tool and on the right-hand side.
	Left finishing	Adds a specific macro for the left finishing operation, when performed by contouring with a milling tool and on the left-hand side.
	Round corner	Adds a specific macro for rounded corners when made with the aggregate.
	Stop	Adds a specific macro for the stop.





















	Stock	Adds a specific macro for stock.
Variables names		
Ab	Edgeband thickness	Defines the name of the edgeband thickness parameter in the encoding.  Warning: the name must not contain any special characters.
Before and after CNC		
	Enable	Allows to specify edgebands placed before or after CNC. If this option is checked, the module will adjust the operation to avoid splintering edgebands. If this box is checked, a window appears during encoding, asking which edgebands are placed on the CNC. Each edgeband is identified by a number.
	Left contouring	Adds a specific macro for partial left contouring.
	Split distance	Length of partial contouring on the left.
	Enable drilling method	If left contouring is not possible, it can be replaced by drilling to avoid splintering the edgeband.
#	Tool ID	WOODWOP tool number for edgeband drilling. Keep 0 if drilling is managed by diameter only.
	Diameter	Diameter of hole to be created. This parameter is mandatory. It must be entered to place the hole in WOODWOP.



c. Edgebands parameters (only for WOODWOP)

To edit the edgeband parameters, click on the button and another window will appear showing all the edgebands available in the SWOOD Design Edgebands library.

i. Editing an edgeband

Selecting an edgeband from the library on the left of the window brings up the following parameters:







Icon	Parameter name	Description						
	Use extended properties	Allows to assign the parameters already defined in a template to this edgeband, instead of having to enter them all several times.						
Ab	Name	<p>If the previous parameter is unchecked <input type="checkbox"/> :</p> <p>Displays the edgeband name, as defined in the Edgebands library.</p> <p>If the previous parameter is checked <input checked="" type="checkbox"/> :</p> <p>Selects the template to be used.</p>						
Gluing								
	Gluing type	<p style="text-align: center;">Gluing type in WOODWOP</p> <table border="1" style="width: 100%; text-align: center;"> <thead> <tr> <th>Easy edge</th> <th>Edge</th> <th>Power edge</th> </tr> </thead> <tbody> <tr> <td></td> <td></td> <td></td> </tr> </tbody> </table>	Easy edge	Edge	Power edge			
Easy edge	Edge	Power edge						
								
	Macro	Adds a specific gluing macro.						
Saw								
	Offset angle C	 Defines a global rotation angle for the saw.						
	Offset when finishing	 Distance of saw line from cut defined when finish is "None".						
	Offset angle when finishing	 Defines the saw line angle in relation to the defined cut when finishing is set to "None". This value is the sum of offset angle C.						
	Enable before round finishing	Allows to make a rounding cut before round finishing.						
	Offset before finishing	Defines the distance of the saw line from the defined cut when the finish is a rounded corner.						

	Offset angle before finishing	Angle of the saw line in relation to the defined cut when the finish is a rounded angle. This value is the sum of the offset angle C.
	Enable cut before flush	When trimming is the finishing operation, this parameter defines the order between trimming and flush trimming.







Round corner

	Enable round corner aggregate	When the finishing is a rounded corner, it is possible to use the aggregate or simply a milling cutter.
---	-------------------------------	---

Flush trimming

	Macro	Adds a specific flush trimming macro.
	Enable anticipation	When one edgeband overlaps another with a rounded corner, anticipation can be used to reduce the risk of edgeband damage. It allows to modify the C value before the corner and to adjust the feed speed while the corner is being flush trimmed.
	Enable techno parameters files	Uses WOODWOP or SWOOD model technologies.
	Techno parameter files	Allows to modify and save a "Technologiemakro" in WOODWOP as a .nca file.
	Anticipation distance	Sets the distance from the anticipation starting point to the corner.
	Anticipation Speed	Defines the speed of the aggregate at the anticipation starting point.
	Anticipation offset	Sets the angle of the anticipation offset.

Scraping (1 ou 2)

	Enable scraping	Adds the scraping operation (Bündigfräsen) at the end of the program (after flush trimming).
	Macro	Sets the scraping macro.
	Enable Anticipation	<p>Allows to change the feed speed during corner scraping. When one edgeband overlaps another with a rounded corner, anticipation can be used to reduce the risk of edgeband damage.</p> <p>The principle is very similar to that of flush trimming, except that the "Technologiemakro" does not include a C modification. It only manages the F value (Feed rate). It only manages the F value (Feed rate).</p>
	Utiliser une macro d'anticipation	Comme pour l'affleurage, utilise les technologies du modèle WOODWOP ou SWOOD.
	Techno parameter files	Allows to modify and save a "Technologiemakro" in WOODWOP as a .nca file.
	Anticipation distance	Sets the distance from the anticipation starting point to the corner.
	Anticipation speed	Defines the speed of the aggregate at the anticipation starting point.

Scraping 1 operations are performed counterclockwise (the tool is on the right). It can also be used in a clockwise direction by activating scraping 2 and checking the Clockwise parameter.

ii. Template management

To avoid modifying the parameters of each edgeband in the edgeband library, it is possible to create templates that can be applied to several edgebands.

To **create a template**, simply click on the " New" button in the window's toolbar.

To **delete a template**, simply click on the " Delete" button in the window's toolbar.

SWOOD CAM – Angle Finishing

With SWOOD 2024, a new operation has been developed to enable concave corners to be completely machined using a conical milling cutter. This operation is called "📄 Angle Finishing".

To be effective, this operation is generally used after a "**Resume pocket angles**" or "**Resume angles using radius compensation**" operation.

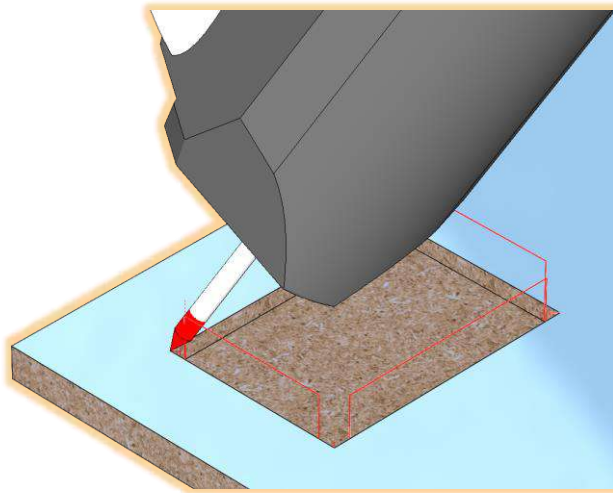







Finishing a pocket corner

I. How to use

1. Operation application

The operation can be applied to the following machining:

<i>Icon</i>	<i>Machining name</i>
	Profile
	Closed sketch
	Open sketch
	Auto pocket
	Closed pocket
	Open pocket

2. Operation creation

Once you have chosen a machining and a compatible tool (Chamfering cutter or Engraving cutter), simply select the  "Angle finishing" operation and "add" it.

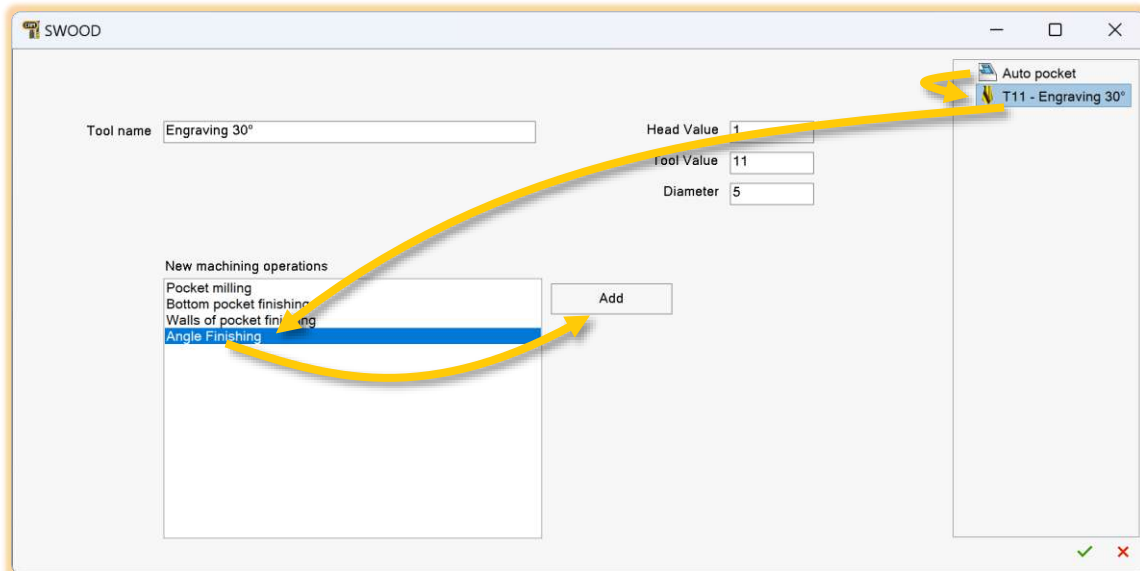

3. Operation parameters

The  "Angle finishing" operation contains the following specific parameters:

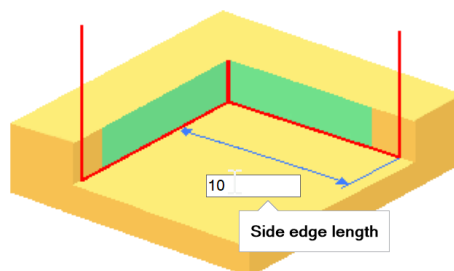

Side edge length: Size at which machining starts; depends on the diameter of previous tools.

a. Transitions

Diagonal transition



Straight transition between two corners to be machined.

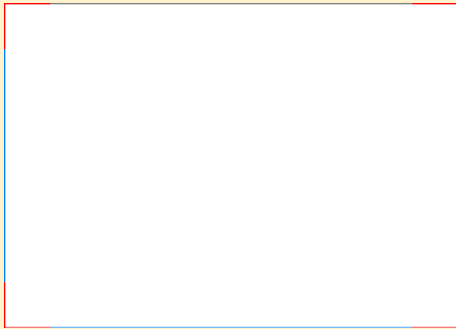

Zigzag transition



Zigzag transition between two corners to be machined.

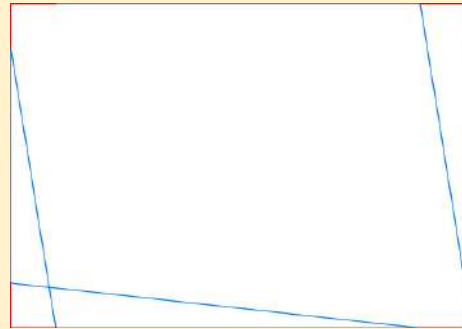

b. Mid-angle trajectories

Without mid-angle trajectory



WITHOUT machining on the bisector of the angle of each corner to be machined.

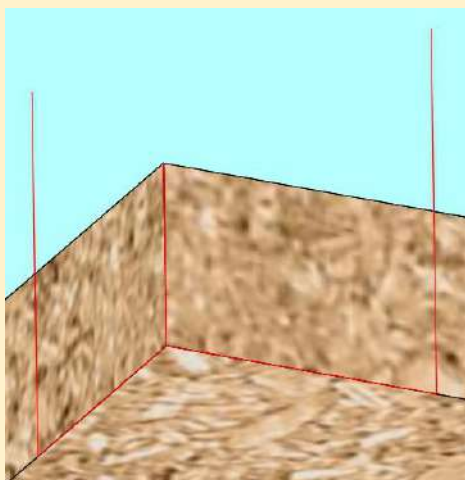

With mid-angle trajectory



WITH machining on the bisector of the angle of each corner to be machined.

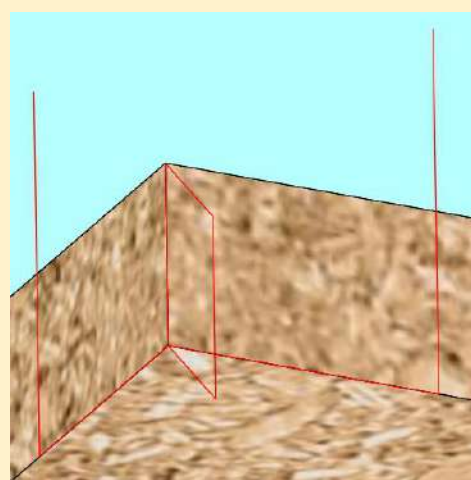

4. Results

With this new feature, pockets with internal corners can now be completely machined.

Without angle finishing

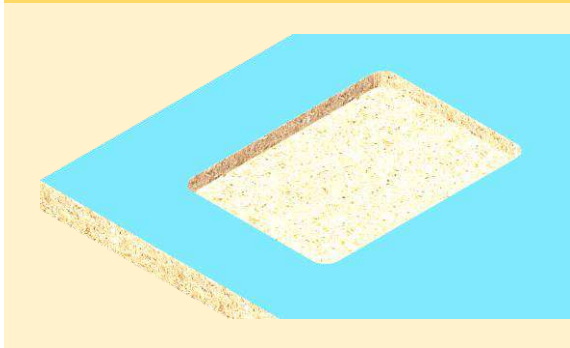

With angle finishing

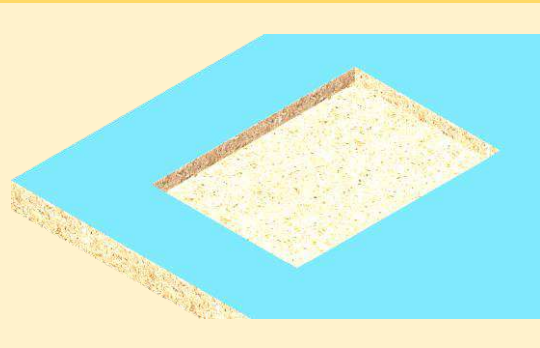

SWOOD CAM - Corner Notching

A new machining operation has been integrated into SWOOD CAM 2024, the "Corner Notching". This operation is the cousin of the Angle Finishing operation, but this time it is used to machine the corners of through-hole profiles, using an angled tool. This operation can be performed after a simple "Contouring" operation.

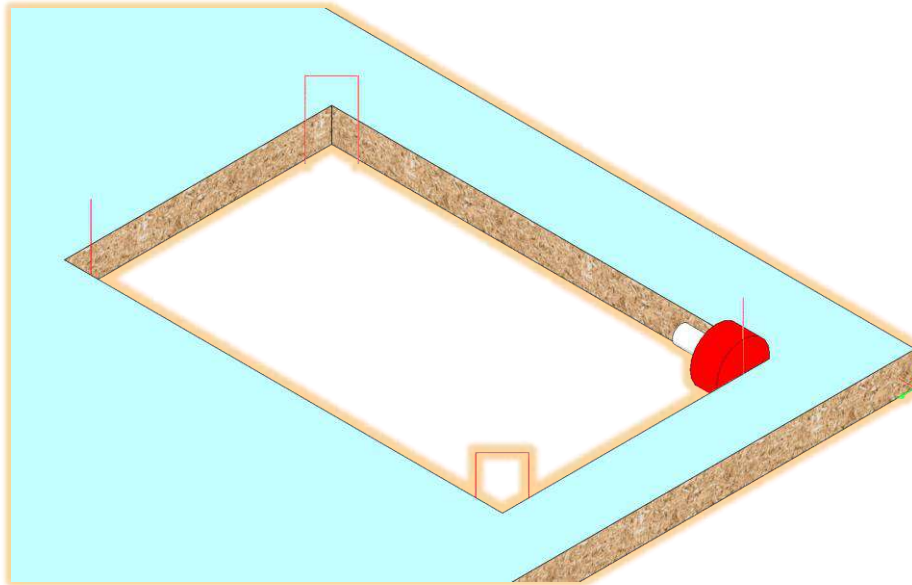



Squaring an inside corner of a through profile

I. How to use

1. Operation application

The operation can be applied to the following machinings:

<i>Icon</i>	<i>Machining name</i>
	Profile
	Closed sketch

2. Operation creation

Once a machining entity and a  saw-type tool (preferably on an angled aggregate) has been chosen, simply select the "Corner Notching" operation and "add" it.

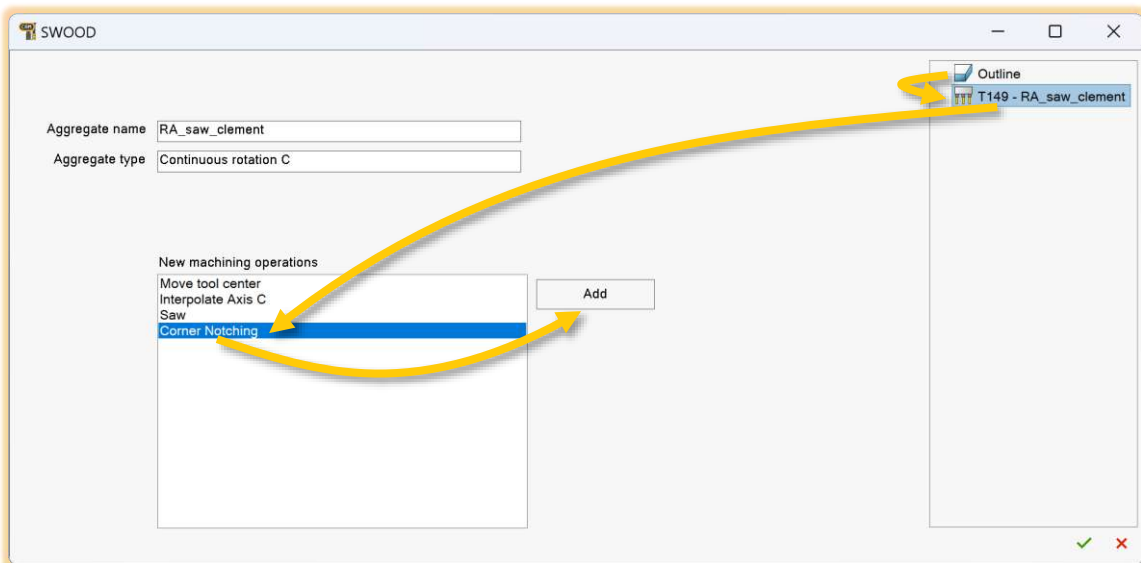

3. Operation parameters

The "Corner Notching" operation contains the following specific parameters:

a. Automatic distance to angle **activated**

By activating this  button, the operation uses the diameter of the previous tool to calculate the distances to the corner, left and right.

b. Automatic distance to angle **deactivated**

If the button is disabled, the left and right corner distances must be entered manually, using the "Distance to angle on left side" and "Right corner distance" parameters.

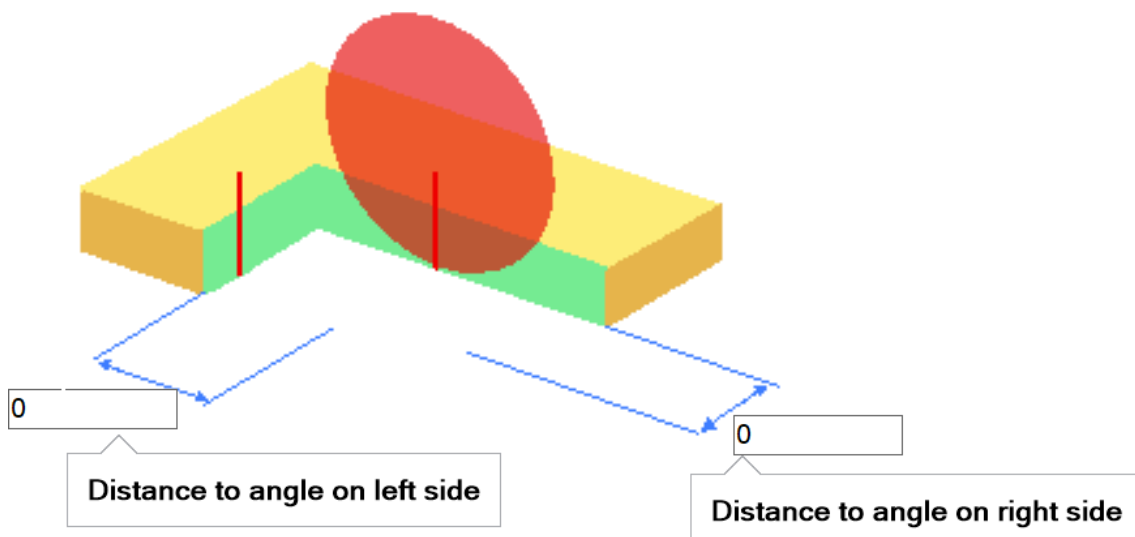

4. Results

With this new feature, it is now possible to completely machine profiles with internal angles.

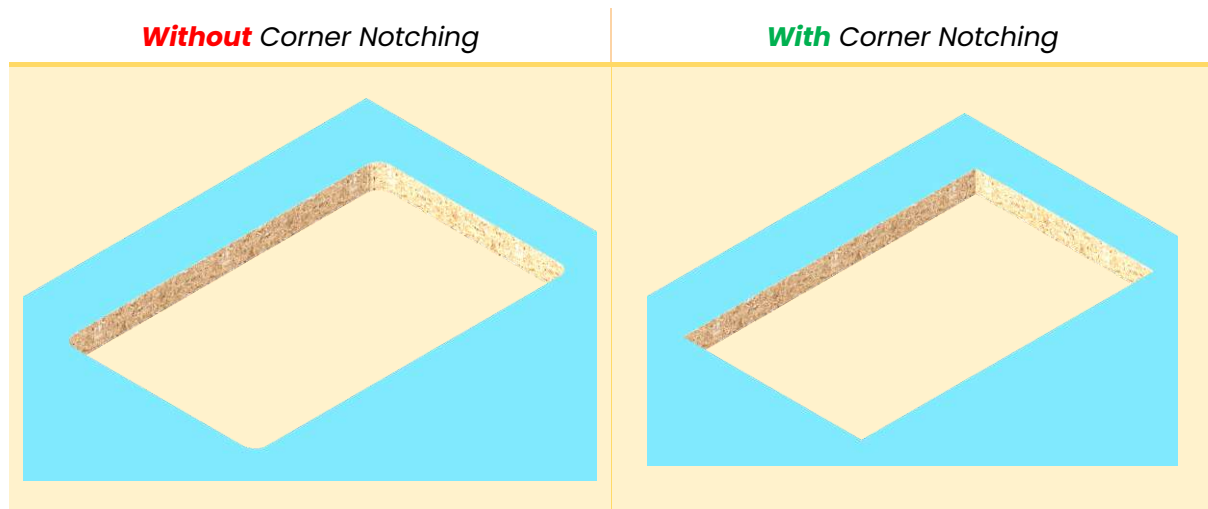

SWOOD CAM – Clamex with milling tool

For several versions of SWOOD CAM, it has been possible to create machining operations with a blade, using **Clamex** connectors. With SWOOD CAM 2024, it is now possible to create these machining operations with a **milling tool**, whether in 3-axis or 5-axis mode.

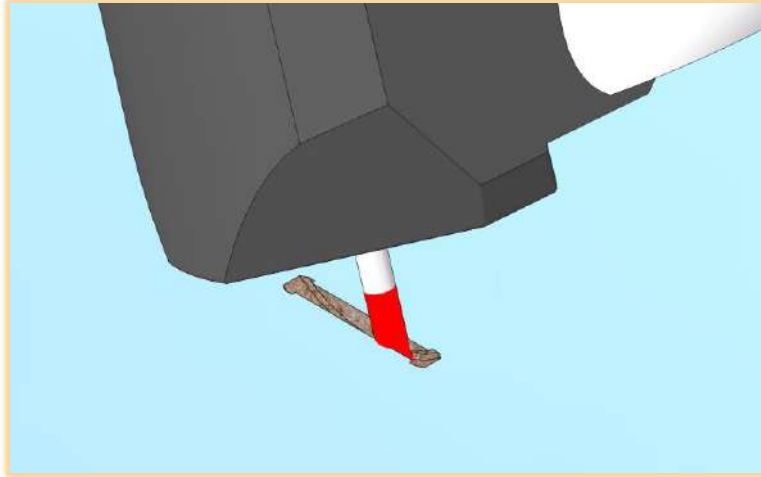

Example of Clamex machining with milling tool

I. How to use

1. Operation application

The "Clamex with milling tool" operation can be applied to a manual or automatic Clamex machining.

2. Operation creation

Simply select the "Clamex with milling tool" operation and "add" it.

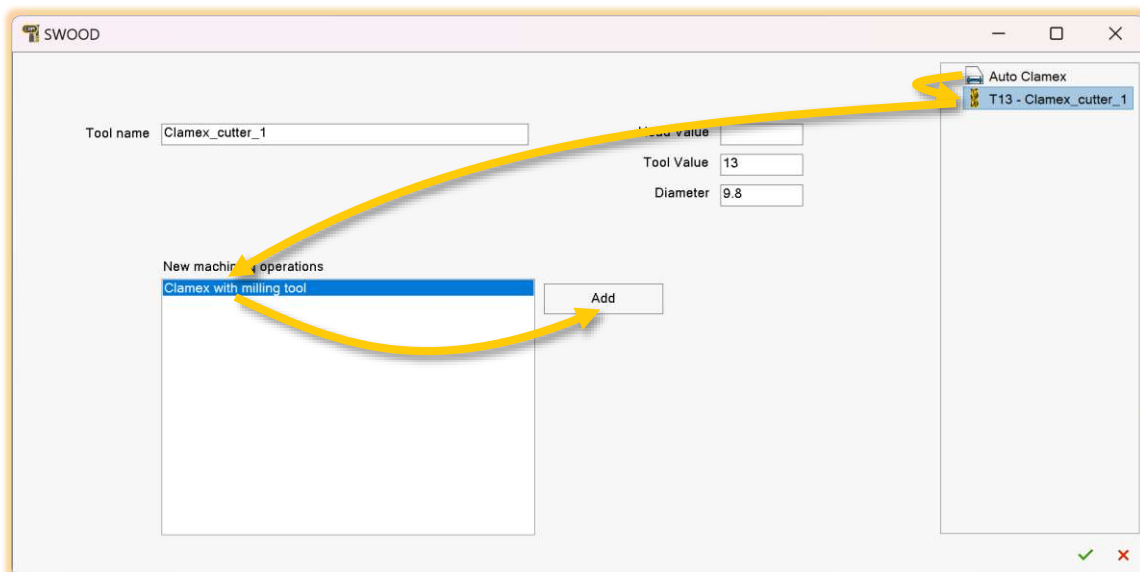

3. Operation parameters

The "Clamex with milling tool" operation contains the following specific parameters:

a. Lead In & Out distance

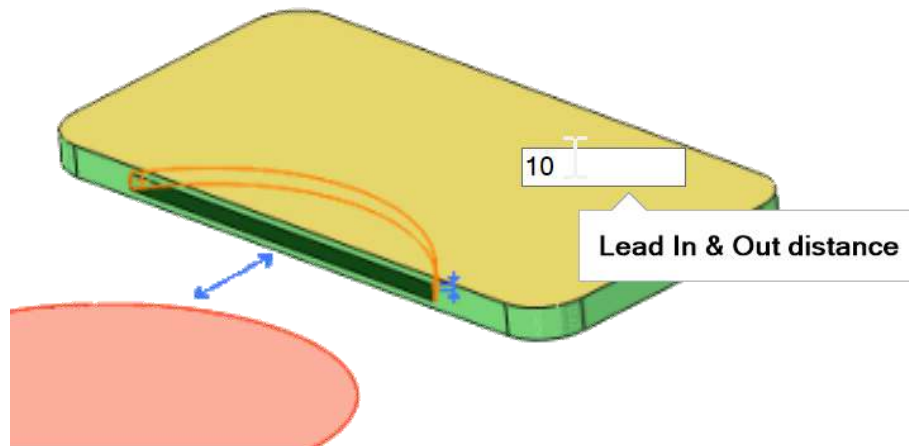

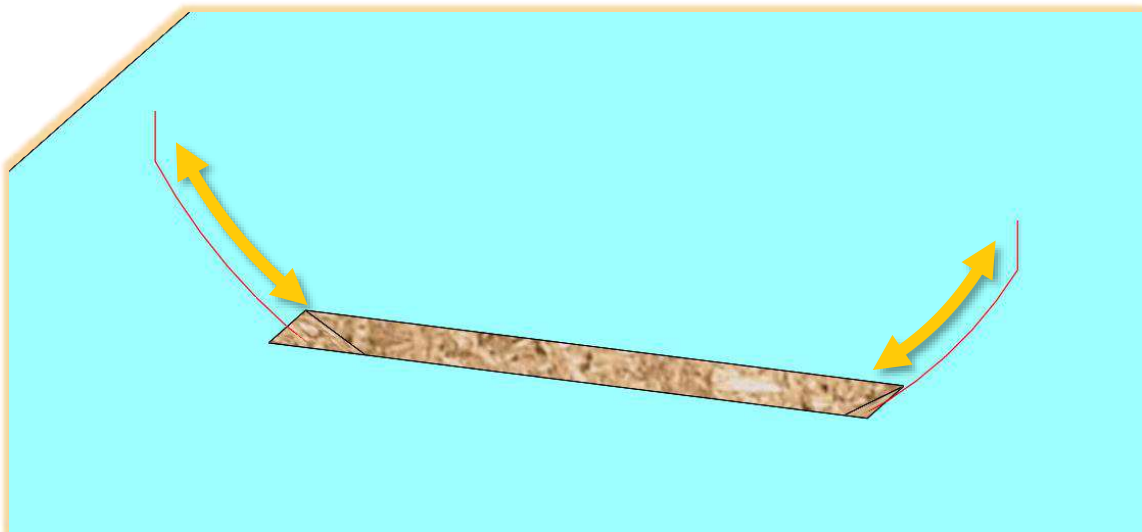

Arc length of machining outside Clamex.



b. 3 / 5 axis milling

The machining button is used to switch between 3-axis and 5-axis machining.

3 axis milling	5 axis milling
	
<p>Angles B and C remain at zero during machining</p>	<p>Angles B and C change to keep the tool axis perpendicular to the surface to be machined</p>

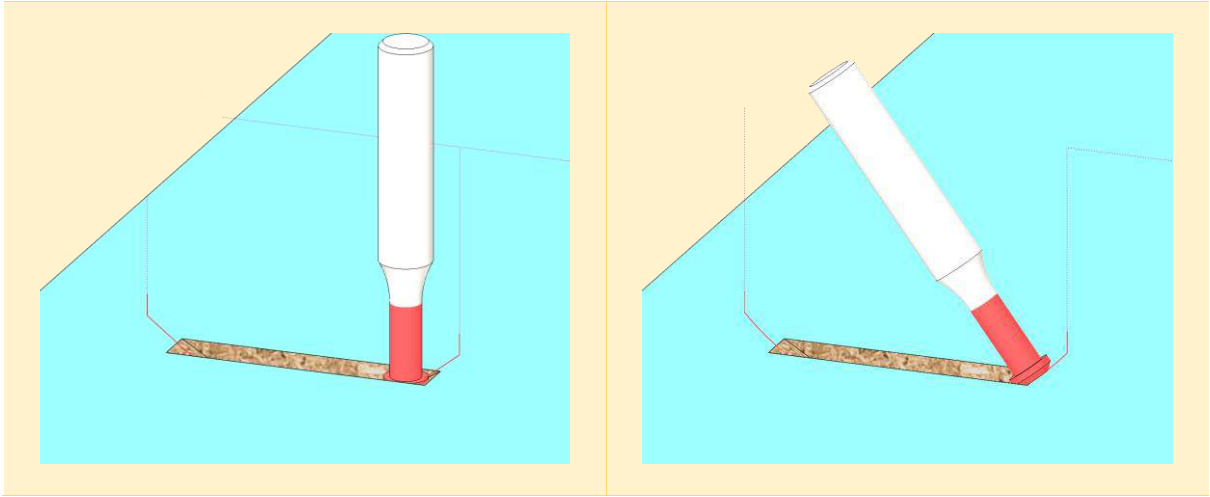

SWOOD CAM – New automatic orientation strategies

When creating the origins of a part, it is possible to select the positioning method based on  automatic recognition (especially for users who do not have SWOOD Design). SWOOD CAM 2024 includes groove recognition options, enabling both the definition of the groove to be recognized for positioning and the orientation of the groove. This last option is particularly relevant for companies using vertical machines, or machines processing all six sides of parts.

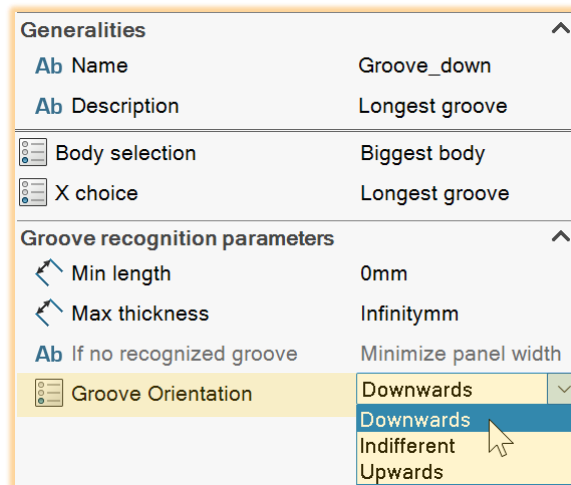





Setting automatic positioning rules



I. How to use

1. Creation of automatic positioning rules

To create automatic positioning rules, it is necessary to:

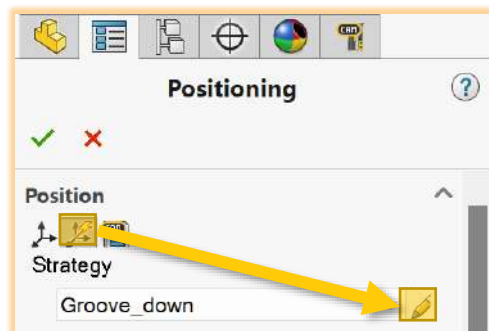
-  Open a SWOOD panel.
-  Créer une phase d'usinage.
- Click on the "  Origins" toolbar button.
- Select "  Based on automatic recognition" mode.
- In "Strategy", click on the  edit button.



-  Create a new configuration.
- In " X choice", select "Longest groove".

2. Groove orientation parameter

The following options are available for " Groove orientation":

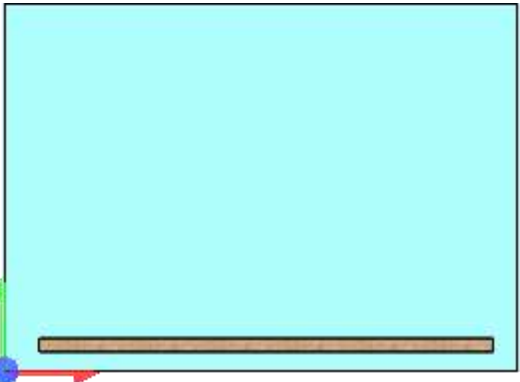
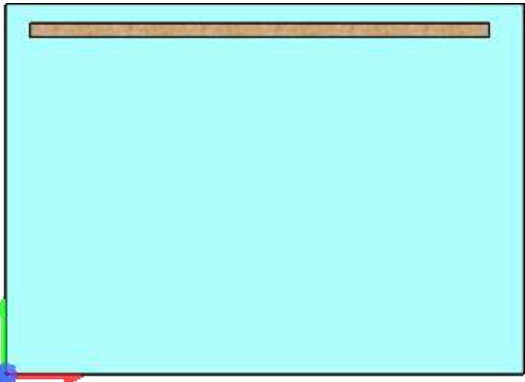
Downwards	Upwards
The longest groove is positioned at the bottom of the panel in relation to its origin	The longest groove is positioned at the top of the panel in relation to its origin
	

SWOOD CAM – Simplified access to "Tools synchronization" and "CAM copy"

SWOOD CAM offers additional tools to make life easier for certain users, such as the "Tools synchronization" tool and the "CAM copy" tool. SWOOD CAM 2024 provides simplified access to these tools, directly in the software interface.

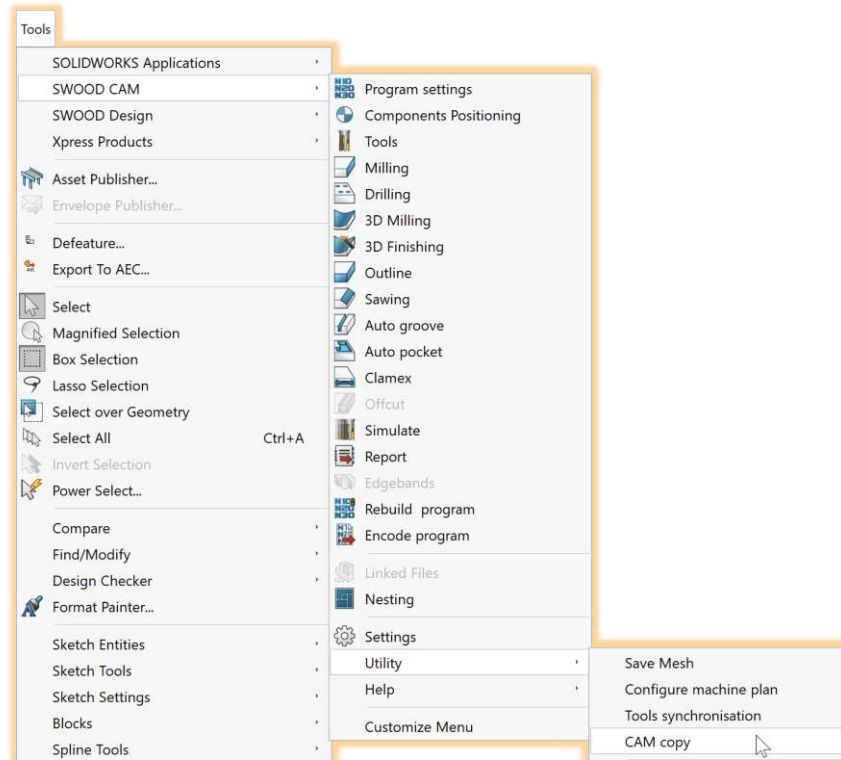

Direct access to tool commands

I. Tools Synchronization

This utility helps to recreate a machine's tool library in the SWOOD CAM tool library.

1. Open "Tools synchronization"

From SWOOD 2024, this utility can be opened from the SolidWorks menu bar:

Tools → SWOOD CAM → Utility → Tools Synchronization

II. CAM copy

This utility is used to copy machining operations from a part or assembly into a file or set of files in a single action.

1. Open "CAM copy"

From SWOOD 2024, this utility can be opened from the SolidWorks menu bar:

Tools → SWOOD CAM → Utility → CAM copy

SWOOD CAM – Report option if no machining to be encoded



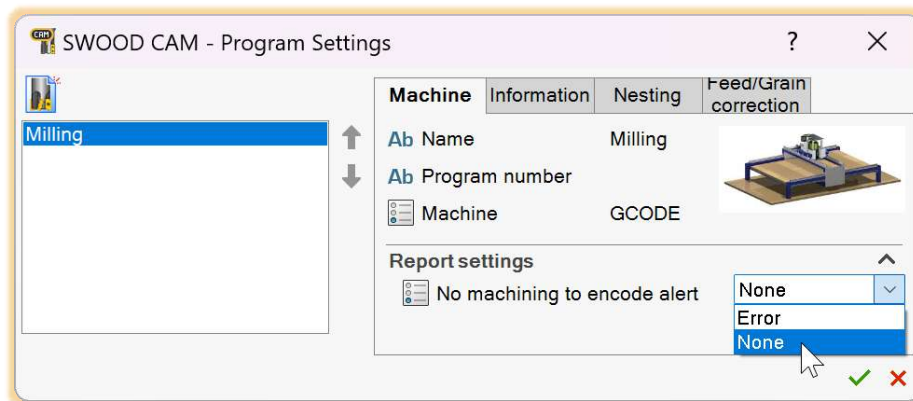

Since SWOOD 2024, it is possible to create a customizable event in the report when there is no machining to code. This can be particularly useful for companies that automate SWOOD CAM, using part or assembly models that already have automatic machining. This new feature will warn them at report time if certain parts do not need to be machined.



Program initialization window with warning selection

I. How to use

To select the warning to be displayed when a program is encoded in the report but does not contain any machining to be coded, it is necessary to:

- Open a  part or an  assembly.
- Create a new  milling phase.
- In the "Report Options" section, there is the " No machining to encode alert" parameter.
- Select "**None**" or "**Error**" option.

II. Result

According to one or other option, with a program that has no machining to code, the results will be as follows:

1. If **None** is checked

If the " No machining to encode alert" report option is set to "None".

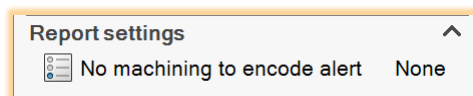

In this case, when a report is generated, there are no errors. Neither in the general variables, nor in the part program.

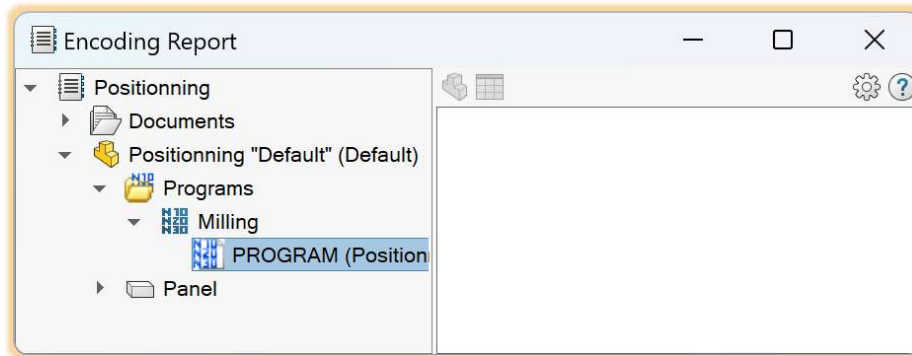

2. If **Error** is checked

If the "No machining to encode alert" report option is set to "Error".

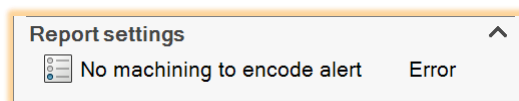

In this case, when a report is generated, an error occurs. In the general parameters, and in the part program.

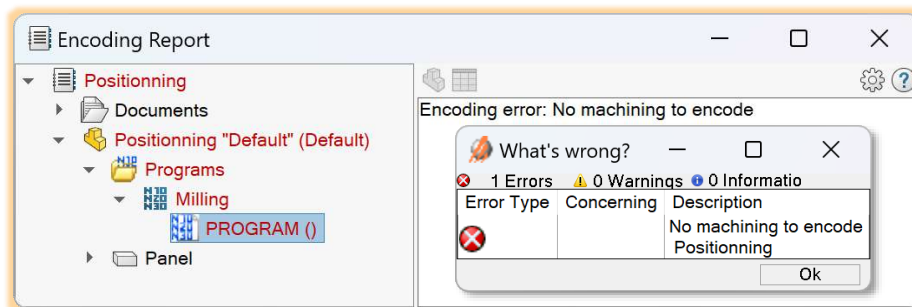

SWOOD Nesting – Ignore grain direction

This new feature allows you to ignore the grain direction if this improves nesting optimization. This feature can be used for parts that will not be visible, such as hidden backs or side panels.

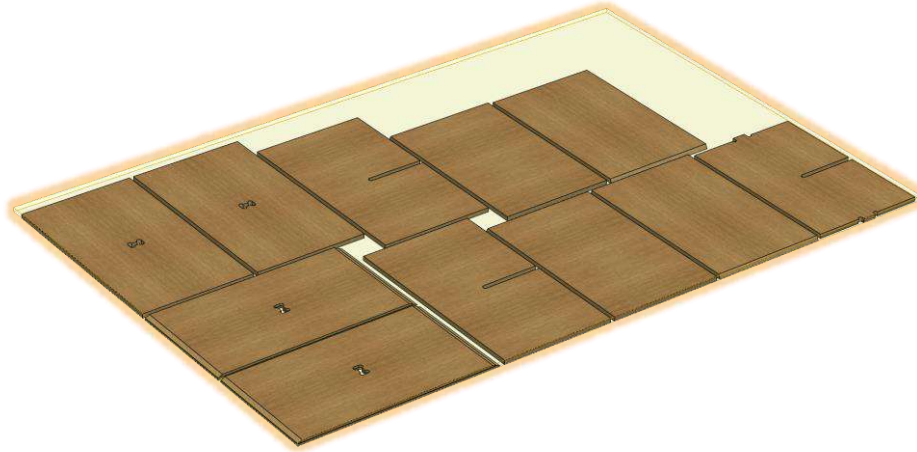







Example of a Nesting project where the grain direction has been ignored

I. How to use

1. Manual parameter

The first way to apply the "Ignore grain direction" parameter is to check it in the parameters of each part to be nested. To do this, it is necessary to:

-  Creating a Nesting project (*Tools* → *SWOOD CAM* →  *Nesting*).
-  Inserting parts to be nested in the project.
-  Go to the "Parts for nesting" folder.
-  Select the part(s) to be nested.
-  At the bottom of the Nesting parameters, check the "Ignore grain direction" parameter.

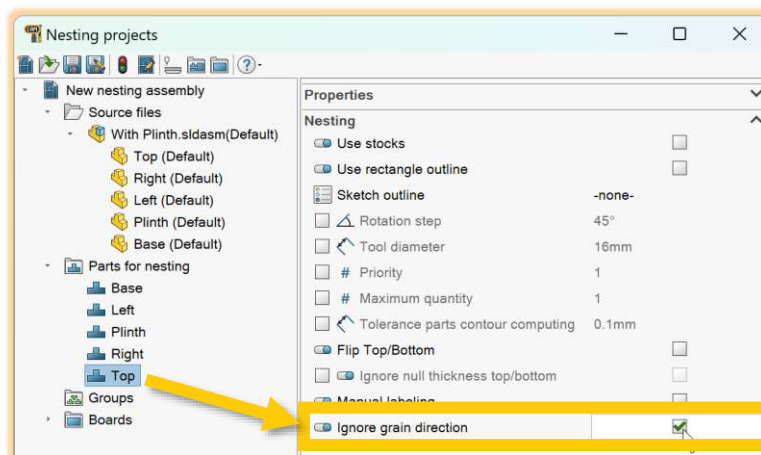



-  Rebuild the Nesting project.

2. Automatic parameter

It is possible to make the process a little more automatic by using custom properties for SolidWorks parts.

To do this, it is necessary to:

-  Open the panel where you want to ignore the grain.
-  Open "File properties".
- Click on the "Custom" tab, or the "Configuration Specific" tab.
- Add a new property:

Name	Type	Value
IGNORE_GRAIN_DIRECTION	"Text" (or "Yes or no")	Yes (to activate)

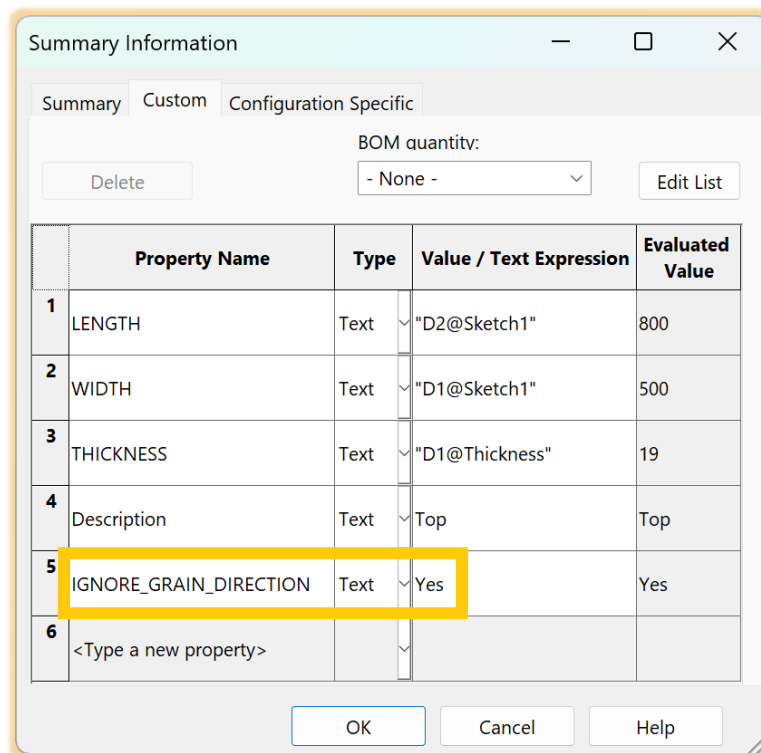

Once this property has been set, the next time Nesting is optimized, the part to be nested will be automatically checked.

II. Result

If the "ignore grain direction" parameter is checked on a part to be nested, then the nesting algorithm will no longer take grain direction into account for this part and will optimize part orientation only according to general nesting parameters (such as  "Rotation step").

SWOOD Nesting – Forcing four corners in part types

This new feature has been created to automatically activate the "Four Corners" mode via "  Part types". This mode places parts differently from normal mode, helping to hold small parts securely on the plate during machining.

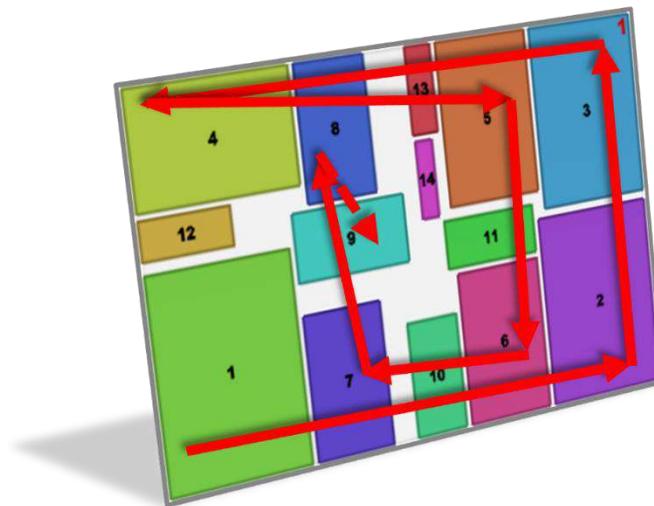

"Four corner" part layout

I. Parts layout

The layout of the parts is as follows:

Regular layout

The parts to be nested are positioned starting from the selected corner in descending order of size.

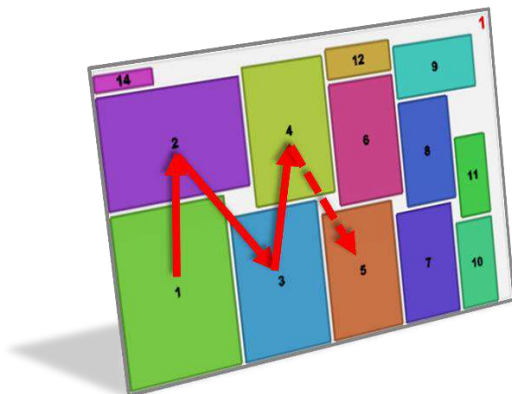



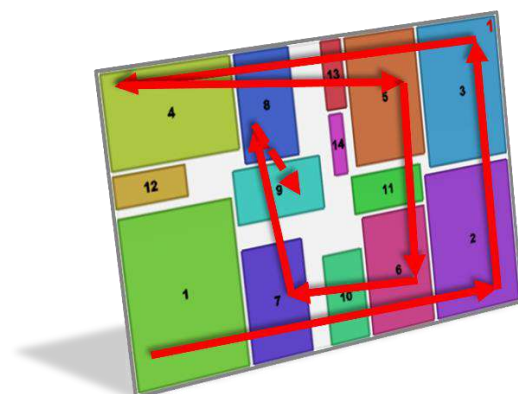

Four corner layout

The parts to be nested are positioned alternately in the **four corners** of the plate in descending order of size.



II. How to use

In order to force the "Four corner" layout in the "Part types", it is necessary to:

-  Create a Nesting project (Tools → SWOOD CAM →  Nesting).
- In the Nesting window toolbar, click on " Part types".
- If no part type exists, create a  new part type.
- In the "Nesting" section, check the "Force four corner" box.

Once the box is checked, another box appears: "Force four corner on last sheet".

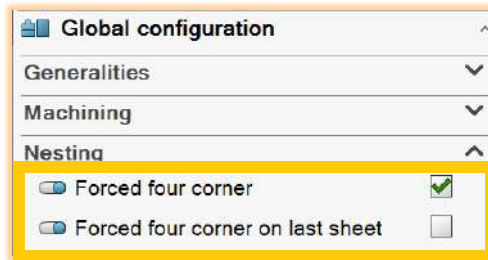

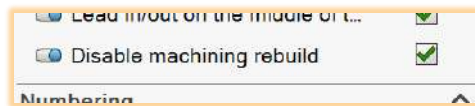

SWOOD Nesting – Disable program recalculation

SWOOD 2024 innovates with a feature designed to further improve nesting efficiency: the option to deactivate automatic recalculation of programs when they are created or modified. This technical innovation specifically targets the challenges associated with the nesting of major components, where recalculation time represents a significant part of the process. Secure and reliable, this function ensures that recalculations are only triggered during program encoding or report generation, optimizing workflow without compromising accuracy. An innovation that promises to transform Nesting management, significantly reducing processing times and boosting productivity.





I. How to use

To deactivate program recalculation, it is necessary to:

-  Create a Nesting project (*Tools* → *SWOOD CAM* →  *Nesting*).
- In the Nesting project window, go to the "Machining" section and check the "Disable machining rebuild" box.

From now on, CAM programs will not be recalculated when the Nesting assembly is created.

They will only be rebuilt under three conditions:

-  If you manually rebuild the program.
-  If you encode the program.
-  If you generate a report.

SWOOD Report – System Report

SWOOD 2024's all-new functionality radically transforms the way professionals interact with their data, thanks to the introduction of system reporting. Designed to suit any company looking to optimize its processes, this innovation is based on a remarkably intuitive user interface accessible from any web browser. What really sets this feature apart is its ability to enable unprecedented customization of data and document display. With just a few clicks, users can modify the appearance of their reports to better suit their specific needs, making workflow not only smoother but also more efficient. This breakthrough illustrates SWOOD's commitment to providing solutions that not only improve productivity, but also transform the way companies manage and present their critical data.

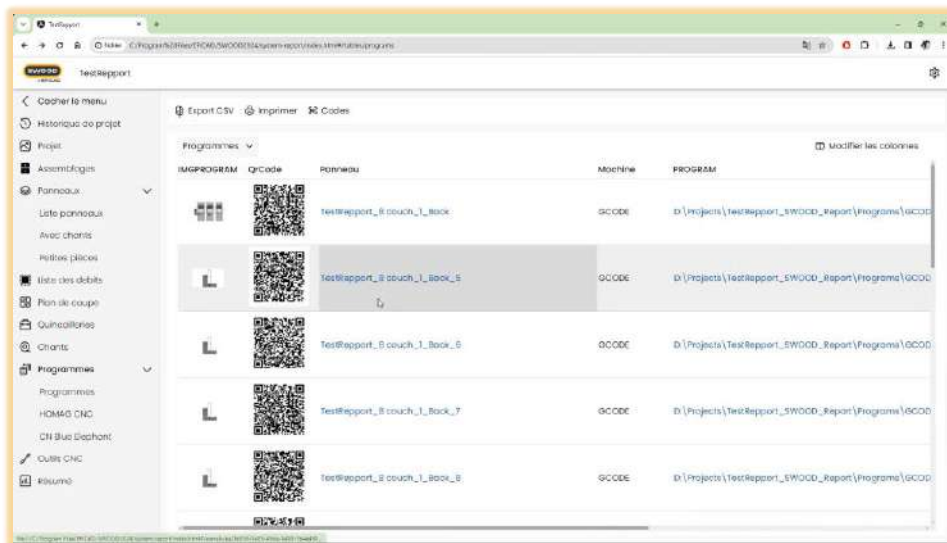
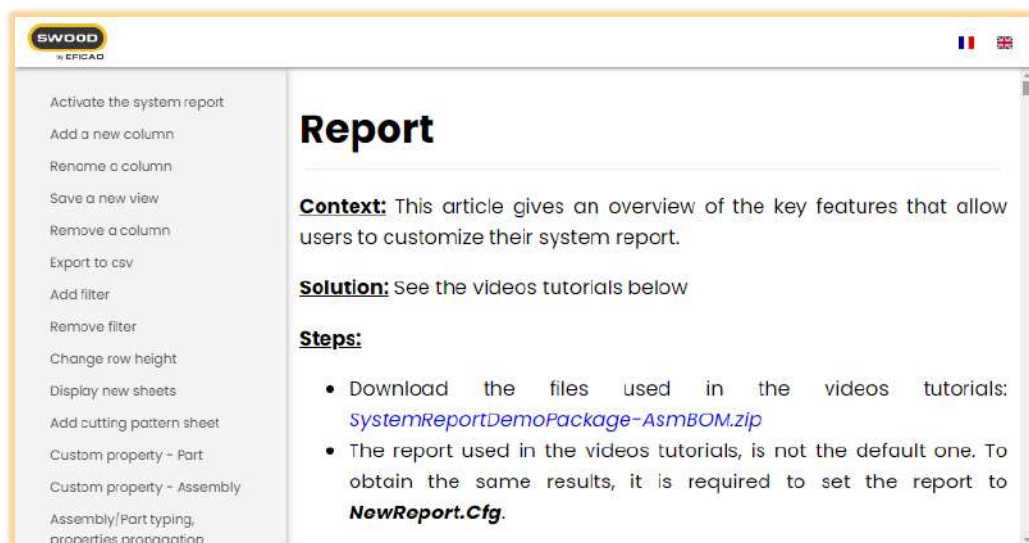

Image	QR Code	Programme	Machine	PROGRAM
		TestReport_8 couch_L_Back	SCODE	D:\Projects\TestReport_SWOOD_Report\Programs\SCODE
		TestReport_8 couch_L_Back_5	SCODE	D:\Projects\TestReport_SWOOD_Report\Programs\SCODE
		TestReport_8 couch_L_Back_5	SCODE	D:\Projects\TestReport_SWOOD_Report\Programs\SCODE
		TestReport_8 couch_L_Back_7	SCODE	D:\Projects\TestReport_SWOOD_Report\Programs\SCODE
		TestReport_8 couch_L_Back_8	SCODE	D:\Projects\TestReport_SWOOD_Report\Programs\SCODE

Example of a page in the system report

To see a **presentation** of the system report, you can [watch this video](#).

To go further in the configuration of the system report, please [consult this page](#):



Activate the system report

Add a new column

Rename a column

Save a new view

Remove a column

Export to csv

Add filter

Remove filter

Change row height

Display new sheets

Add cutting pattern sheet

Custom property - Part

Custom property - Assembly

Assembly/Part typing, properties propagation

Report

Context: This article gives an overview of the key features that allow users to customize their system report.

Solution: See the videos tutorials below

Steps:

- Download the files used in the videos tutorials: [SystemReportDemoPackage-AsmBOM.zip](#)
- The report used in the videos tutorials, is not the default one. To obtain the same results, it is required to set the report to **NewReport.Cfg**.

I. How to use

1. System report installation

a. Activation

To take full advantage of this new system report, you first need to activate the system report.

To do this, it is necessary to:

- Open the "⚙️ Settings" window in SWOOD Design or SWOOD CAM.
- In the "Report" section, click on the 🖋️ system report edit button.
- Activate "System Report".

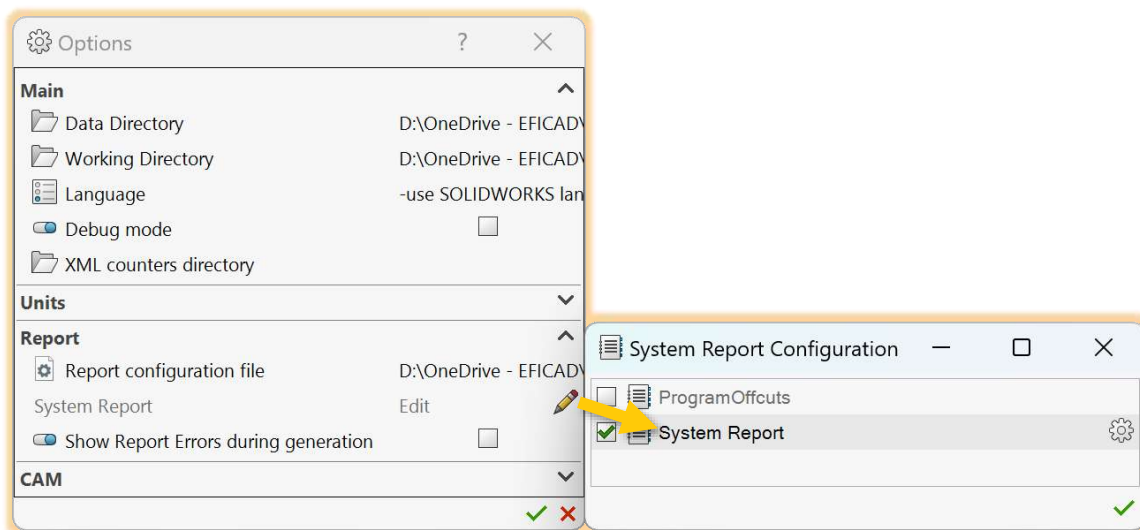

To better understand how to **activate the system report**, you can [watch this video](#).

b. System report generation

As for generating a classic report, go to the menu bar and select:

Tools → SWOOD Design (or SWOOD CAM) → 📄 Report

In the report window, expand "📁 Documents" and open the HTML page "🌐 SYSTEM_REPORT".

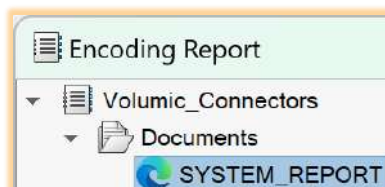

2. System report interface

The system report page is divided into 4 sections:

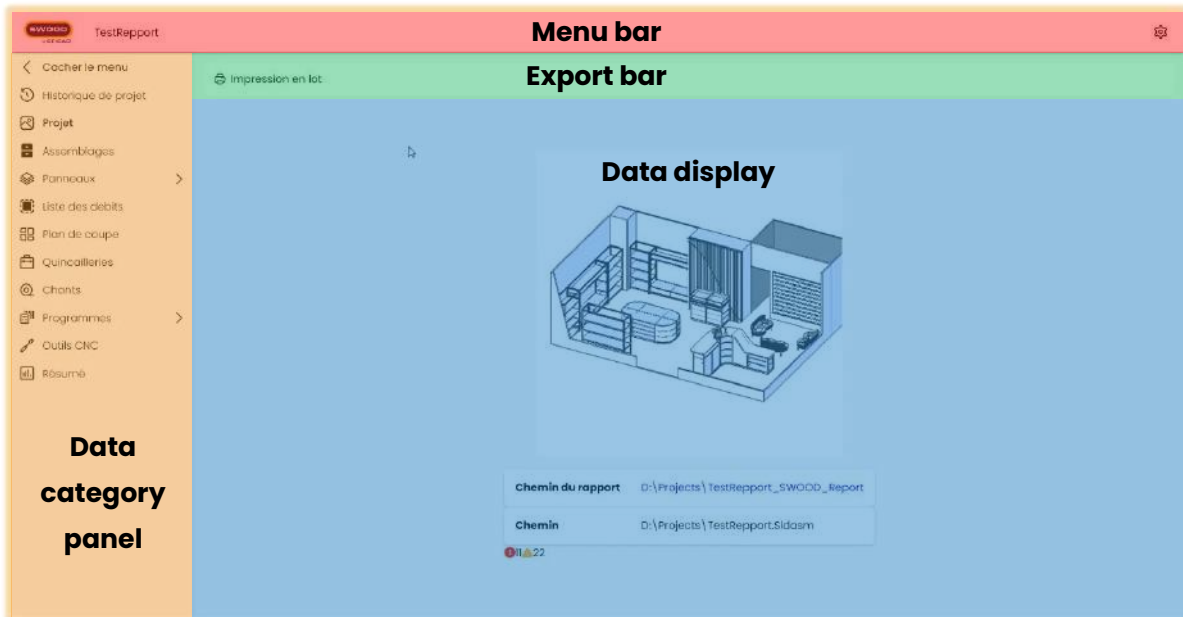

- **Menu bar** (top): Displays the company logo, the name of the current project and, on the right, the  parameters.
- **Data category panel** (left): Displays data categories on the main view (the choice of categories to be displayed is made in the parameters).
- **Export bar** (below menu bar): Enables the user to export the data displayed in the main view, as a printout or CSV export.
- **Data display**: Main data view, depending on the data category selected in the left panel.

a. Parameters

To access the parameters, click on the  gear on the far right of the menu bar (accessible on all pages). Settings have three tabs:

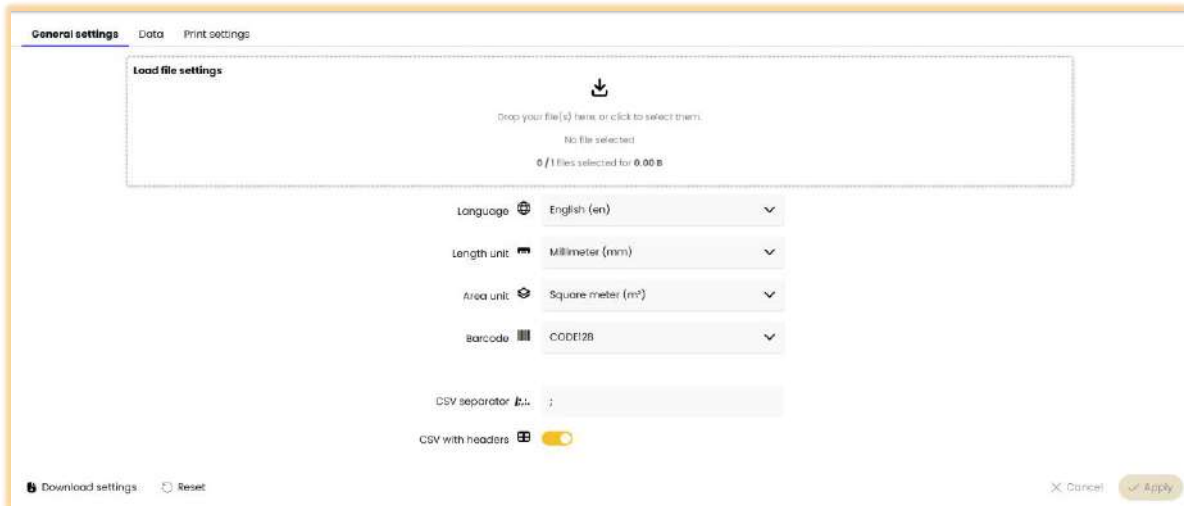

i. General parameters

In the general parameters, it is possible to import an existing configuration and set display parameters such as language, units of length, etc...



ii. Data

In this window, it is possible to choose which data categories will be displayed in the data category panel (left).

On the right-hand side, the available data can be  transferred to the left-hand side, with the data categories displayed. Alternatively, you can hide certain data categories with the button  to the right.

The order of data categories can be changed by dragging and dropping, while holding down the  six dots.

These categories will be displayed in the data category panel only if the displayed project contains data.

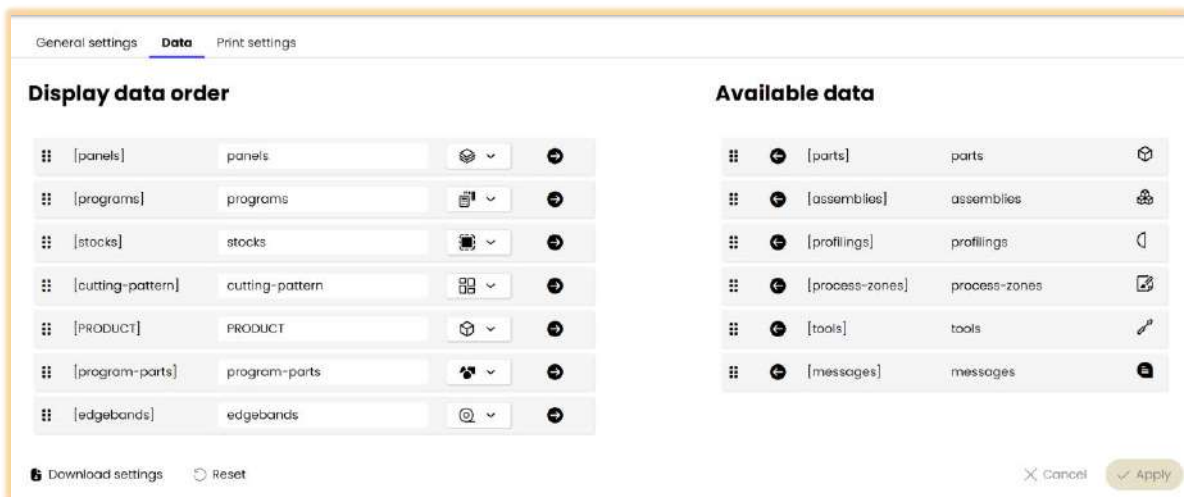

To better understand how to **add a new data category** to your system report, [watch this video](#).

iii. Print settings

In this window, it is possible to set print parameters, such as header image, specific table views, etc...

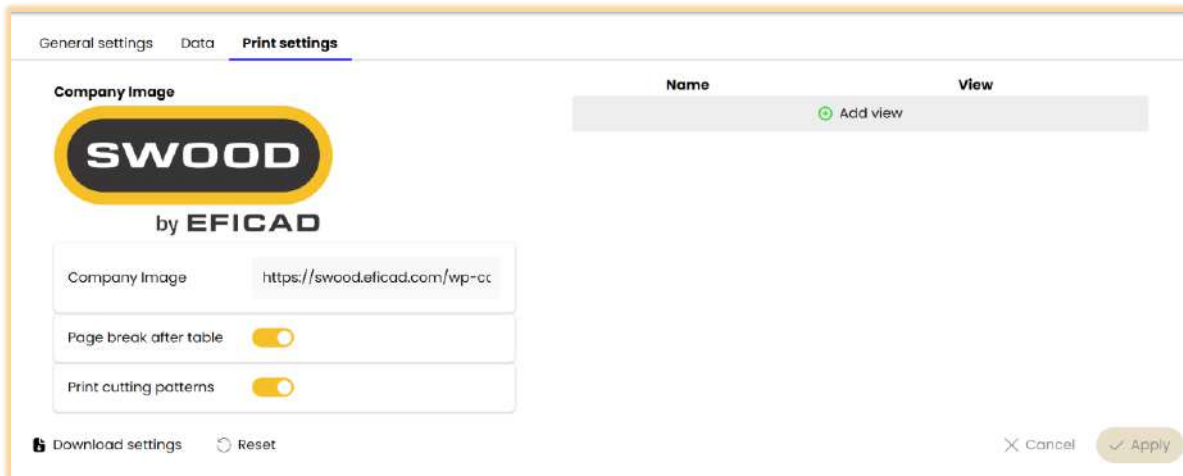

b. Data categories

Data categories display project data by type of information.

i. Permanent categories

There are 3 categories that are always present, whatever the project data:



Project History: This category shows all projects that have been opened previously.

It is also possible to import a project that has been generated by another PC. To do this, click on "Project file" or drag and drop on this section. The file extension to be imported is SWR (specific to SWOOD system reports).

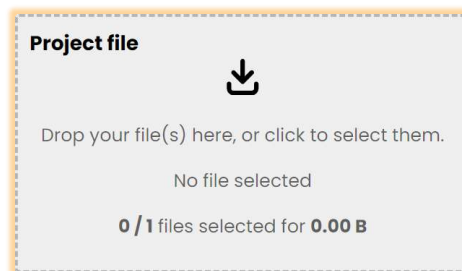

Project: This category displays the current project with project image, report path and SolidWorks file path.









 **summary:** The "Summary" category of data sums up the costs of all types of data, such as edgebands, materials, cutting patterns, machining, etc...

Machines					
4569,82 €					
Nom	Coût horaire	Nb de programmes	Temps	Coût (€)	
GCODE	60,00	37	01 : 25 : 17.0	85,28	
WOODWOP-5X	80,00	118	56 : 03 : 24.0	4484,53	



Chants	20,99 €
Matériaux	944,86 €
Schéma de coupe	77,50 €
Machines	4569,82 €

ii. Project categories

Numerous categories can be displayed in the category panel, such as  assemblies,  panels,  stock,  hardware,  edgebands,  programs, etc...

It is possible to choose which categories are to be displayed in the panel, and in which order, from the "Data" tab of the settings.

c. Data display

Except for certain data categories such as  Project,  Cutting Plan and  Summary, all data categories are presented in table format.

i. Manipulating tables

Data tables have been created to display the values most relevant to users. These tables can therefore be customized.

The table interface is divided into 3 sections:

The screenshot shows a table interface with three distinct sections:

- Filter bar (top):** Contains a dropdown menu labeled 'Vue par défaut', a title 'Filter bar', and three icons with labels: 'Modifier les colonnes', 'Filtre', and 'Recherche'.
- Data columns (middle):** A table with 6 columns: 'Nom du matériau', 'Longueur du débit (mm)', 'Largeur débit (mm)', 'Epaisseur du débit (mm)', 'Panneau', and 'Quantité'. The table contains 7 rows of data. A red box highlights the first four columns, labeled 'Data columns'.
- Page management (bottom):** A green bar containing the text 'Page management' and pagination controls: '1-6 de 6', navigation arrows, '1/1', and '10'.

- **Filter bar**





In this section, you can customize the display of data columns. Several tools are available for this purpose (from left to right):

- Views

A view is a kind of "snapshot" of a table in a particular state, with its columns and filters.

You can display a preset view by clicking on the  down arrow and selecting it.

The following view options are available:

Icon	Option name	Description
	View settings	Modify view parameters by adding one or more custom columns
	Save as	Saves the display status of the panel in a new view
	Add to favorites / Remove from favorites	Adds or removes this view to the data category favorites, directly accessible from the data category panel
	Delete	Deletes the selected view from the saved views

To better understand how to **add a new view** to a table, you can [watch this video](#).

- Modify columns

When you click on the "☰ Modify columns" button, a panel appears on the right with two tabs:

- *Sort*

This tab allows you to change the column order by simply dragging and dropping existing columns. You can even add an empty column.

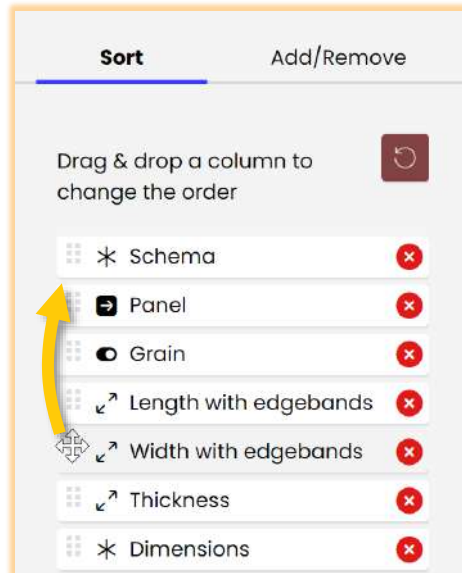

To better understand how to **manage current columns** in a table, [watch this video](#).

- *Add/Remove.*

This tab lets you add or remove columns from the current view. In this tab, you can find all report parameters, and turn them into a column.

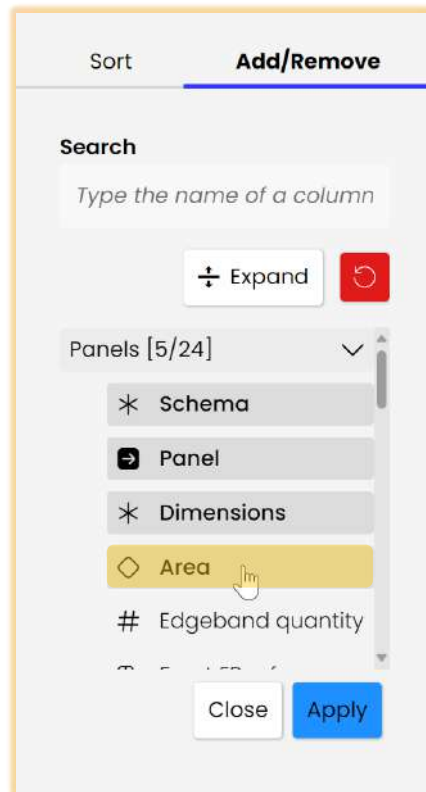

To better understand how to **add a new column** to a table, you can [watch this video](#).

- Filters

It is possible to display the contents of columns by filtering according to certain rules. When you click on "Filter", a window opens, offering you to apply filters or groups of filters.

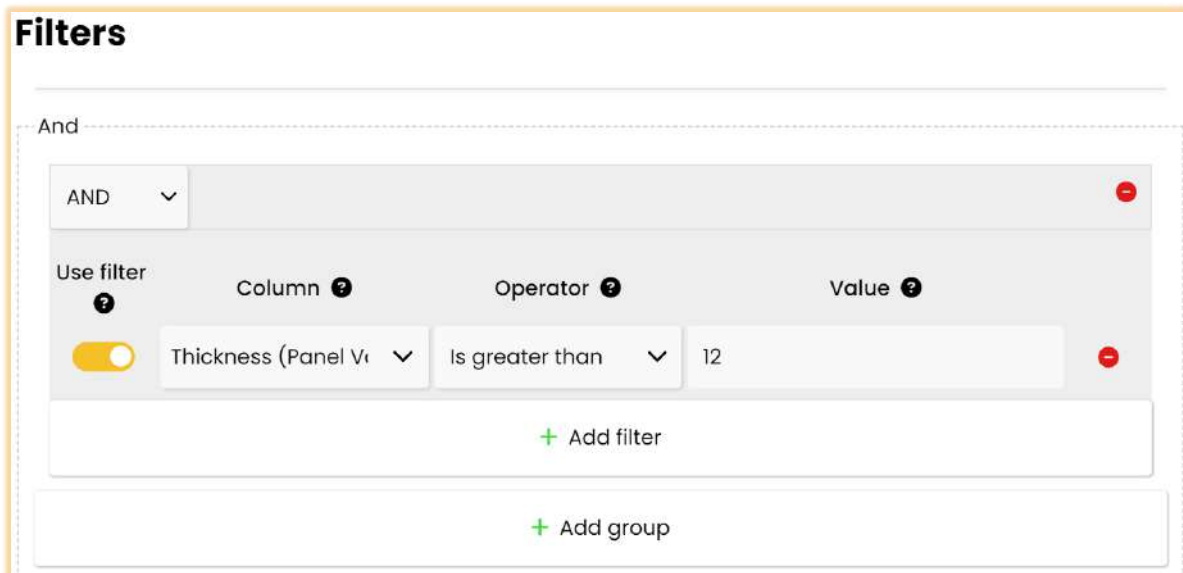

To better understand how to **create and apply filters** to a table view, [watch this video](#).

To better understand how to **remove a filter** from a table view, [watch this video](#).

- Lines height

It is possible to adjust the  height of lines in the table display according to 3 different heights: compact, medium, or spaced.



To better understand how to **adjust the height of the lines** in a table, you can [watch this video](#).





- Search bar

You can easily find a table element using the search bar. This search is not case-sensitive. You can enter only part of the word you are looking for.

- **Data columns**

The data columns section displays the selected columns with their respective filters.

Next to each column name, as you move the cursor closer, a downward arrow appears. By clicking on it, several options are available:

Icon	Option name	Description
	Ascending sorting	Sorts each line of the table from the smallest value to the largest . If the row is composed of text, sort in alphabetical order .
	Descending sort	Sorts each line of the table from the largest value to the smallest . If the row is composed of text, sorts in reverse alphabetical order .
	Create filter	Create a filter that applies only to values of the column.  Warning: column filters will not be saved in the view.
	Rename column	Allows to rename the column.

To better understand how to **rename a table column**, [watch this video](#).

- Column width adjustment

Column widths can be adjusted to display data more clearly. Several options are available:

- *Manual column adjustment*

When the mouse cursor is close to the separation between two columns on the column header line, the cursor becomes an $\leftarrow\| \rightarrow$ adjustment tool. This allows you to enlarge or reduce the column width.

- *Automatic column adjustment*

When the column width $\leftarrow\| \rightarrow$ adjustment tool is visible when double-clicked, the column width automatically adjusts to the most suitable width, allowing the text in that column to be read at its best.

- *Automatic adjustment of all columns*



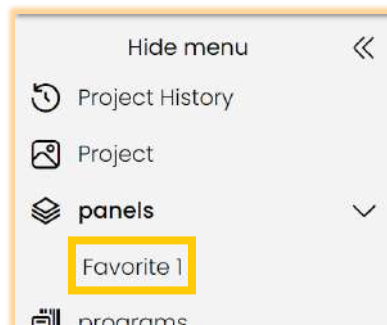

If you place the mouse cursor to the far right of the column heading line, when you double-click on the adjustment tool, the width of all table columns is suddenly adjusted to the space required for reading the data.

ii. Favorites management

As we saw earlier, it is possible to set a view as a favorite. Once a favorite has been created, we can see it appear in the data category menu.



Clicking on this favorite directly from the data category menu opens the favorite table in read-only mode and displays a menu bar above the table.

Icon	Option name	Description
	CSV export	Allows you to export table contents in CSV format.
	Print	Allows you to print the contents of the table.
	Modify the view	Allows you to edit the table view, adding or deleting columns, filters, etc.
	Remove from favorites	Removes the view from the favorites list.

SWOOD Report – Cutting Pattern

SWOOD 2024 enhances its functionality with a tool from the SWOOD report: the creation of a cutting diagram for the panels used, accessible without the need for a SWOOD CAM Nesting license. This function is based on advanced panel optimization, using data from the material and board library, offering double added value. On the one hand, it provides a precise estimate of the number of sheets needed to complete a project, enabling a more accurate evaluation of the associated costs. Secondly, it generates a detailed cutting diagram, which can be used directly in the workshop for manual sawing of panels. This innovation represents a step forward in resource optimization and project planning, simplifying the preparation and management of materials in the production process.

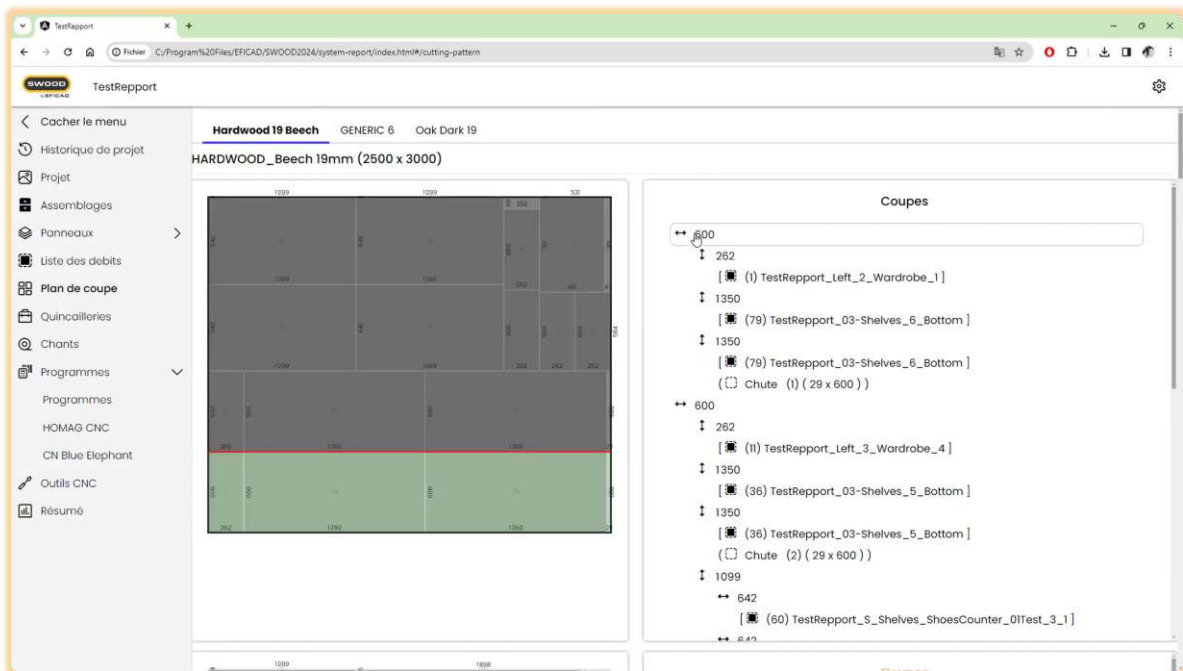

Example of a project cutting pattern

For a **presentation** of the cutting diagram, [watch this video](#).

I. How to use

1. Cutting pattern activation

a. Cutting pattern generation

To activate this cutting pattern feature, you must first [activate the system report](#).

Next, you need to  configure the system report.

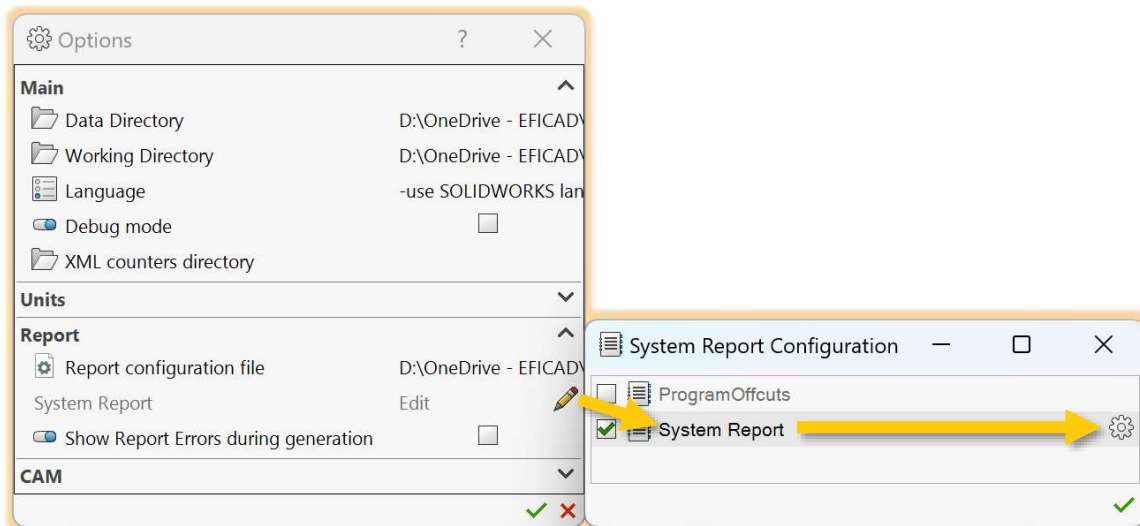

In the "Report configuration" window, click on "🌐 Global variables" in the left-hand panel.

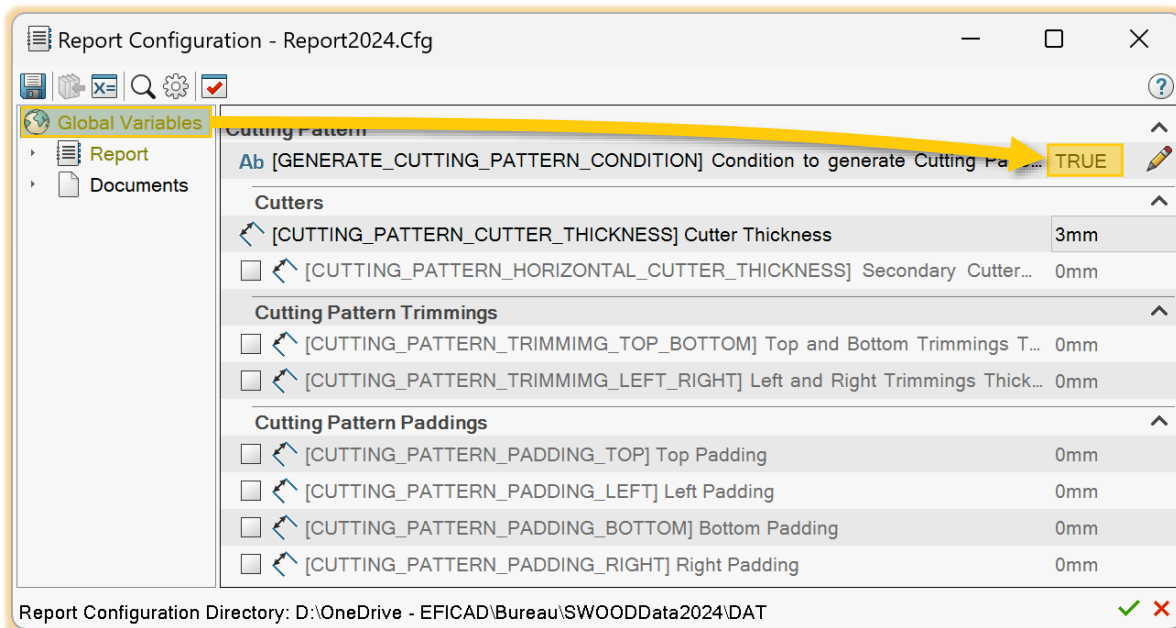

In the "Cutting pattern" section, change the cutting pattern condition. Write **TRUE** (instead of FALSE).



The rest of the parameters in the "Cutting pattern" section can be modified to fine-tune the optimization result, such as saw thickness or cutting margins.

b. Board creation

The second step is to create boards from the  Materials library. To do this, it is necessary to:

- Go to the SWOOD library .
- Go to Materials library .
- Right-click on a material and click on "✎ Edit".

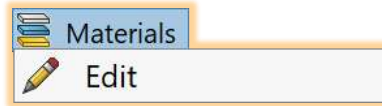

- In the toolbar of the Materials Library window, click on the "Board Library" button (available even when SWOOD CAM is not activated).
- In this board library, create a new board and fill in at least the following five parameters:
 - « For Board Estimation », this parameter activates the board for the cutting pattern.
 - "Length" of the board used.
 - "Width" of the board used.
 - "Thickness" of the board used.
 - "Materials" of the board used.

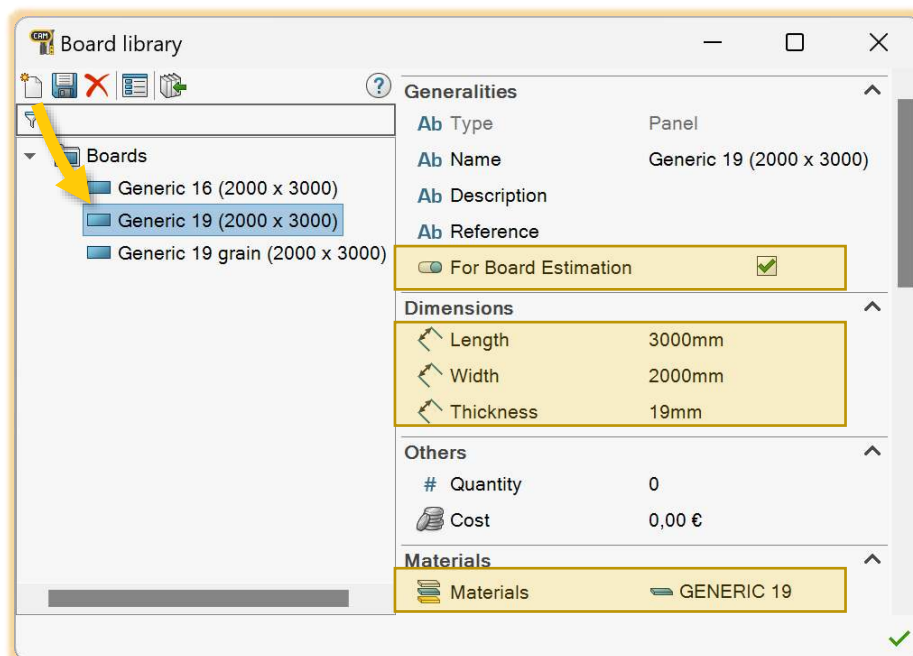

- Validate both windows.

c. Displaying the Cutting pattern in the system report

The final step is to integrate the Cutting Pattern into the system report, so that it can be visualized. To do this, it is necessary to:

- Generate a report.
- In the report window, expand "Documents" and open the HTML page "SYSTEM_REPORT".

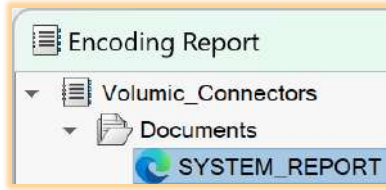

- On the report page (for more details, see the [System Report](#) chapter), go to parameters.

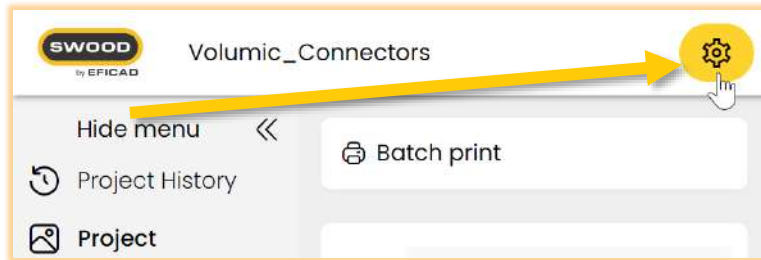

- In the parameters, go to the "Data" tab.
- Locate "Cutting-pattern" and click the left arrow button.

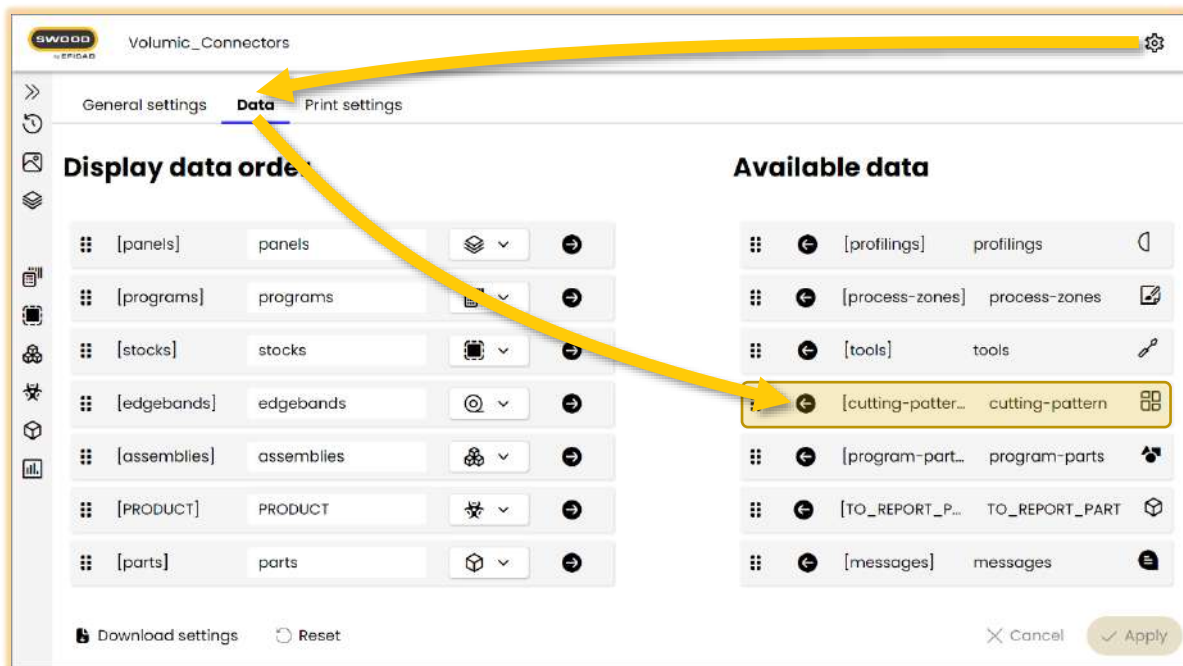

- Click on the "Apply" button (bottom right). Now the "Cutting-pattern" tab is available on the left panel.
- Click on the "Cutting-pattern" tab.

2. Cutting pattern interface

The "Cutting-pattern" tab is divided into 4 sections:

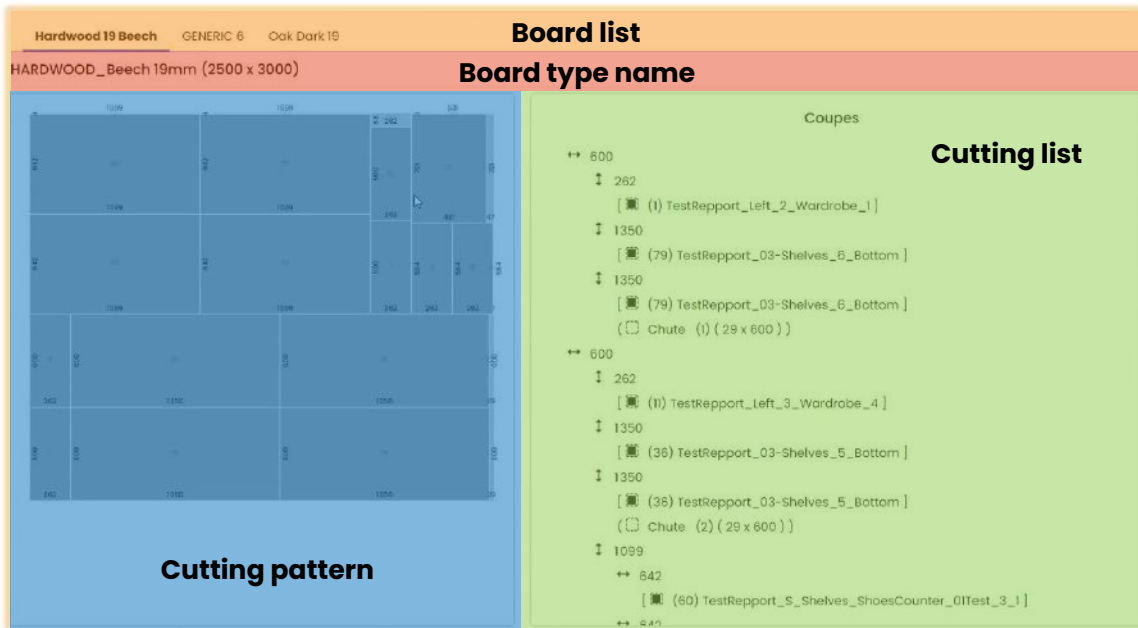

- **Board list:** Displays all board types present in the project. You can switch from one to another simply by clicking on it.
- **Board type name:** Displays the name of the selected board type.
- **Cutting pattern:** Graphic area where the parts are positioned on the board.
- **Cutting list:** Displays the order of the main cuts, followed by the secondary cuts. Clicking on a cut displays it in the graphic area of the cutting pattern.



By navigating with the ↑ up and ↓ down arrows on the keyboard, it's possible to switch from one cut to another.

3. Export

The cutting pattern can be exported simply by clicking on the "Print" button at the top left of the cutting pattern.

Print 

This will create a layout ready for printing or saving as a PDF. This can be very useful to transfer to the workshop.

